

Yard Ramp Options

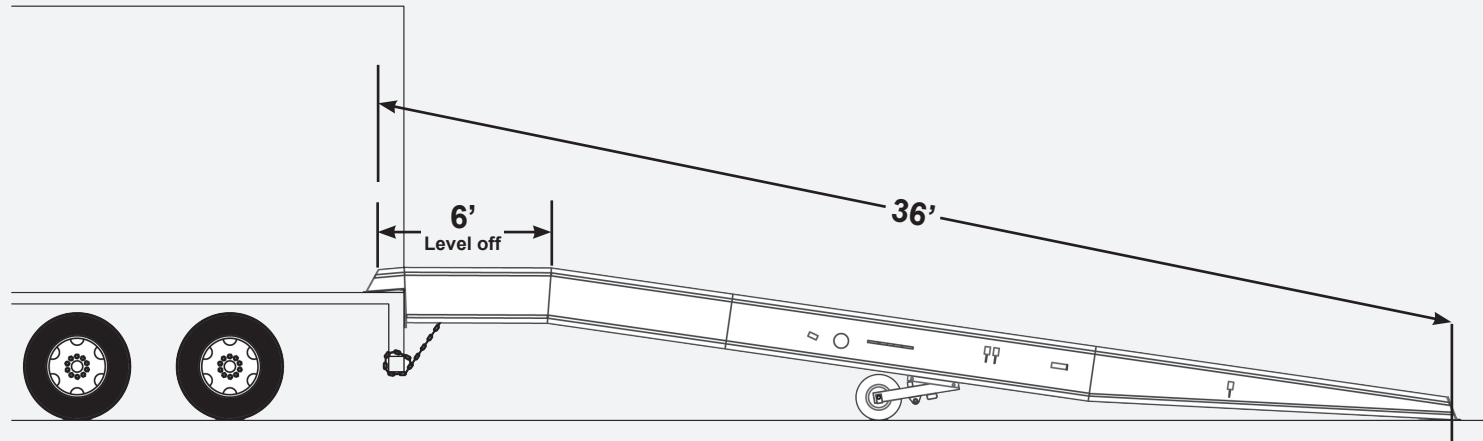

Note: 48-52" typical truck bed equals ramp grade of $\pm 14\%$

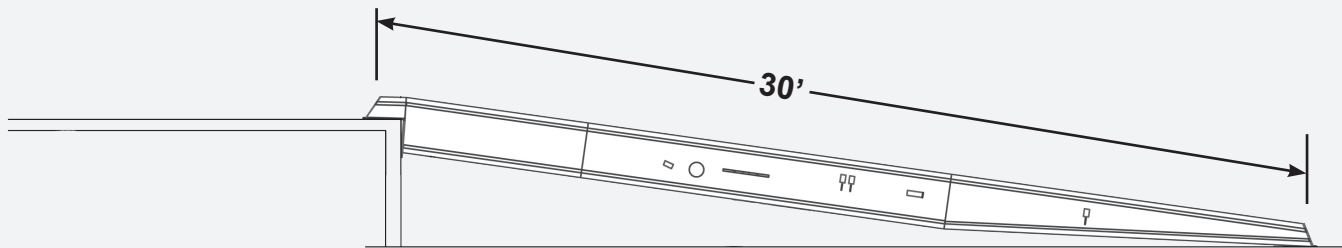

Model	Overall Width	Inside Width	Length	Lip Section
<input type="checkbox"/> YD 70 30	70"	64"	30'	15"
<input type="checkbox"/> YD 84 30	84"	78"	30'	15"
<input type="checkbox"/> YD 70 36	70"	64"	36'	15"
<input type="checkbox"/> YD 84 36	84"	78"	36'	15"
<input type="checkbox"/> Other Size				

Custom length and widths are available
 * Note 36' units include 6' level-off section

Capacity
<input type="checkbox"/> 16,000 lbs
<input type="checkbox"/> 20,000 lbs
<input type="checkbox"/> 25,000 lbs
<input type="checkbox"/> 30,000 lbs



A Division of Systems, LLC

W194 N11481 McCormick Drive • Germantown, WI 53022
 Phone: 1.800.624.8473 • Email: sales@wbmcguire.com
www.wbmcguire.com

DISTRIBUTED BY:

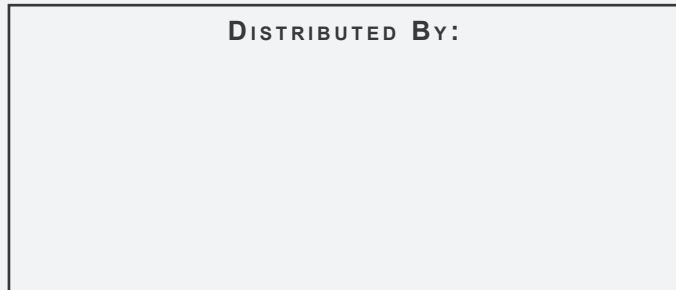

YARD RAMP

PORTABLE STEEL RAMP

Versatile Design For Your Yard Ramp Requirements

Ideal For:

- Dock to grade applications
- Loading and unloading freight carriers
- Loading and unloading rail cars
- New construction sites
- Temporary shipping yards or mounted stationary positions



MADE IN THE USA

PORTABLE STEEL YARD RAMP



The "Tow Clamp" connects between the ramp pocket and the tow hitch of your fork truck and permits easy transportation of the lift over longer distances.

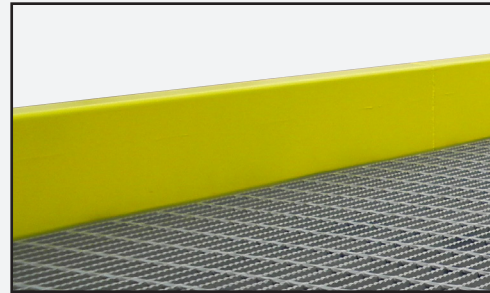

High visibility 8" yellow run-off guards.

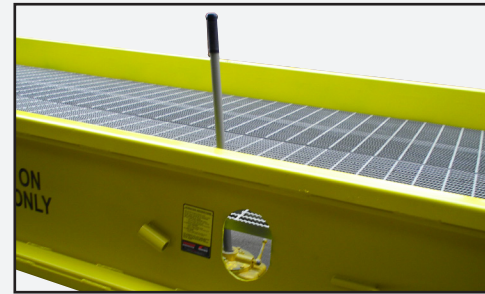

Hydraulic adjustment system permits fast reliable height adjustment of the yard ramp with virtually any trailer bed height. Note: maximum raised height of 36' unit is 70" and 30' is 80".



72" long "level-off" section is standard on all 36' long units to permit easy access for "end-loads" and added mobility of lift trucks. Note: Longer level-off sections are available for custom applications. The shorter 30' ramp is ideal for ground to dock access applications where "level-off" is not required.



15" lip section provides for a smooth transition on and off the carrier bed.

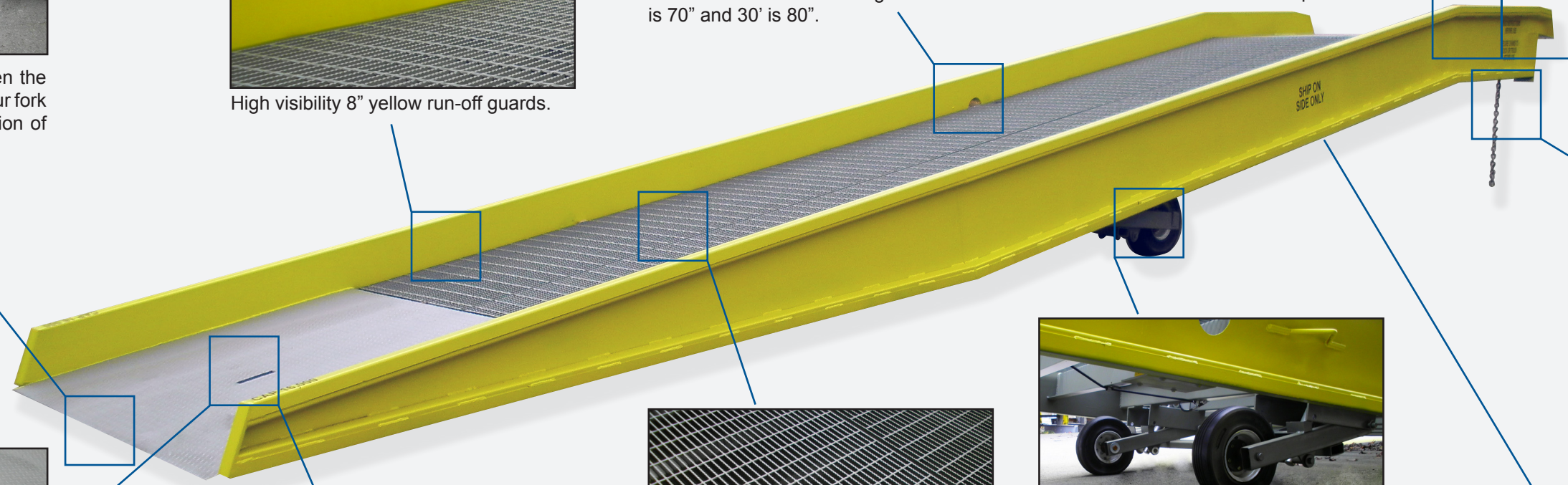

Safety chains hold the ramp tight to the carrier and assure adequate lip purchase is maintained with the carrier bed.



Heavy duty axle assembly with 18" industrial solid rubber tires adds a high level of mobility to the yard ramp for easy positioning. Note: axle can be removed or raised for permanent dock ramp installations.

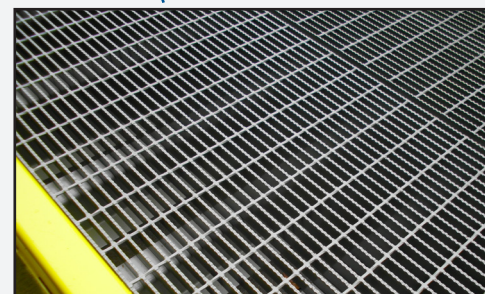

Serrated bar grating provides excellent traction. The open web design prevents build up of debris, rain, snow, oil and grease.



A 60" transition at grade and 30" transition at dock height is constructed of high strength diamond tread plate beveled and recessed for smooth transition onto and off the yard ramp.



The "Fork Clamp" permits easy positioning of the ramp over short distances. Fork clamp inserts into the ramp pocket and clamps onto the fork blade.

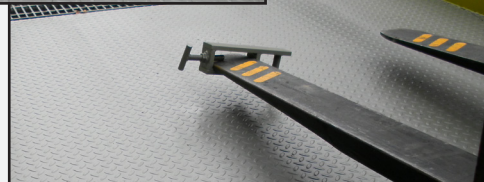

Structure consists of heavy duty formed steel side girders fully welded to high strength steel joists. (Picture shows under side of ramp)

