

**LOADING DOCK SEALS & SHELTERS**



- ▶ **Consistent and Efficient Seal Across Varying Trailer Heights**
- ▶ **Sealing Efficiency Protects Personnel & Property**
- ▶ **Increases Loading Dock Safety While Improving Comfort & Productivity**
- ▶ **Available as a Single Unit with "L" Style Side Pads or Header Retrofits Existing Installed Seals & Shelters**
- ▶ **Unique Patented Head Pivot Assembly Provides Automatic Positioning & Tension for a Tight Seal**
- ▶ **Tightly Seals the Entire Width of the Trailer Roof, Blocks Water**
- ▶ **Yellow Guide Stripes on the "L" Pad Assist the Driver in Positioning the Trailer**
- ▶ **Bottom Filler Panel at Each "L" Pad Aids in Preventing Air Flow into the Loading Dock Area**
- ▶ **Rough Flex™ Base Fabric with Superior Performance Max Flex™ Reinforcement on Header & "L" Pads Provide Maximum Durability**



**SPECIFICATIONS**

Specifications: Dock seal/shelter shall be Series TC \_\_\_\_\_ as provided by McGuire®. Each unit shall be designed to accommodate an opening size up to \_\_\_\_\_ wide x \_\_\_\_\_ high; having a \_\_\_\_\_" dock height; equipped with \_\_\_\_\_" projection dock bumpers. Unit shall be designed to service vehicles ranging in height from \_\_\_\_\_ to \_\_\_\_\_. Each unit shall be constructed of (2) side pads of an "L" style design and (1) head frame assembly with a spring bias head pad system having the following O.D. dimensions: 11'-2" wide x 11'-0" high x 16" projection.

The head and side pads shall be constructed having a Rough Flex™ base material; with the entire contact face of both side and head pads further reinforced with superior performance Max Flex™ material.

Head frames shall be constructed of structural steel tubing having all welded joints with translucent fiberglass secured to the exterior.

Each unit shall include one pair of self positioning, independent panels equipped with Durapleat® pleats designed to close the transition gap between the face of the head and side pads, while providing additional reinforcement to this area.

Head pad pivot mechanism will provide positioning and tensioning for the head member to create a weather tight seal at the top of the vehicle. Each unit shall include a front and rear head curtain to conceal and protect the head pad pivot assembly from the elements. All hardware shall be galvanized steel.

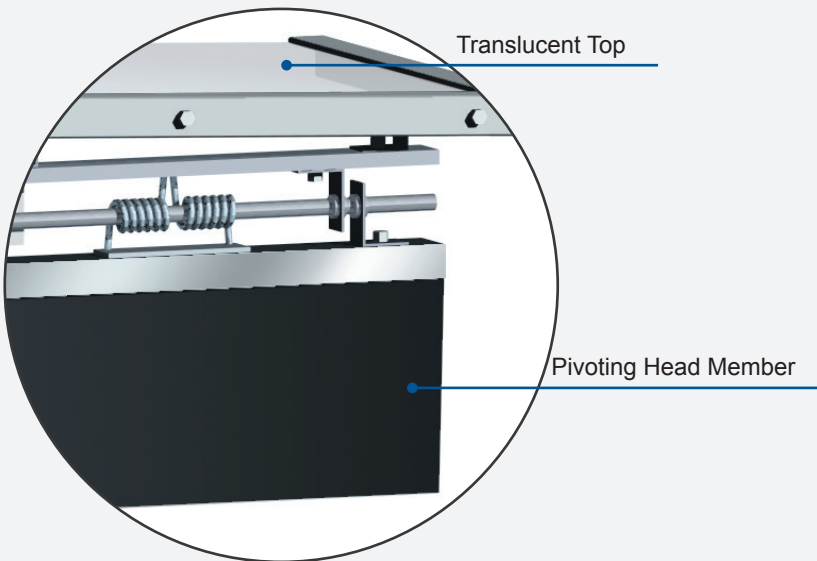

		Options
Basic Fabric:	▶	Rough Flex with Max Flex™ on header and L-pads
reinforcement	▶	Head Pad assembly for use with existing seals or shelters
Options	▶	Additional Projections
	▶	Tapered Units



205 Broadview Street • Upper Sandusky, OH 43351  
 Phone: 1.800.262.1188 • Email: sales@wbmcguire.com  
[www.wbmcguire.com](http://www.wbmcguire.com)

**DISTRIBUTED BY:**