

# Yard Ramp

## Specification Sheet & Submittal



### Capacity Guidelines for Yard Ramps

The capacity you choose must be greater than the total gross moving load (GML); this equals the weight of the fork truck itself plus the weight of the load it carries. Systems, Inc recommends that you then double that figure and use that number as the basis for your weight capacity choice.

### What does “Usable width of my yard ramp” mean?

Yard ramps widths are shown in the table below. The 70” and 84” widths are far and away the most common, with the 84” model used most often for specialized applications. Width of the ramp should be at least 15” wider than the widest equipment to be used on the ramp.

### YARD RAMP LENGTHS & TYPES

#### Straight , 30’ Length Yard Ramp

This type is used primarily for ground/grade level to loading dock applications, where no Level off space is required.

#### Level off , 36’ Length Yard Ramp

A six-foot Level off space at the end of the yard ramp adds maneuverability for forklifts. This allows forklifts easier turning access and allows them to handle pallets next to the door openings. The 36’ ramp is most popular where end-loading is required. This allows the fork truck to be on a level approach and correctly positioned for retrieval of end-loaded pallets.

# Yard Ramp Options

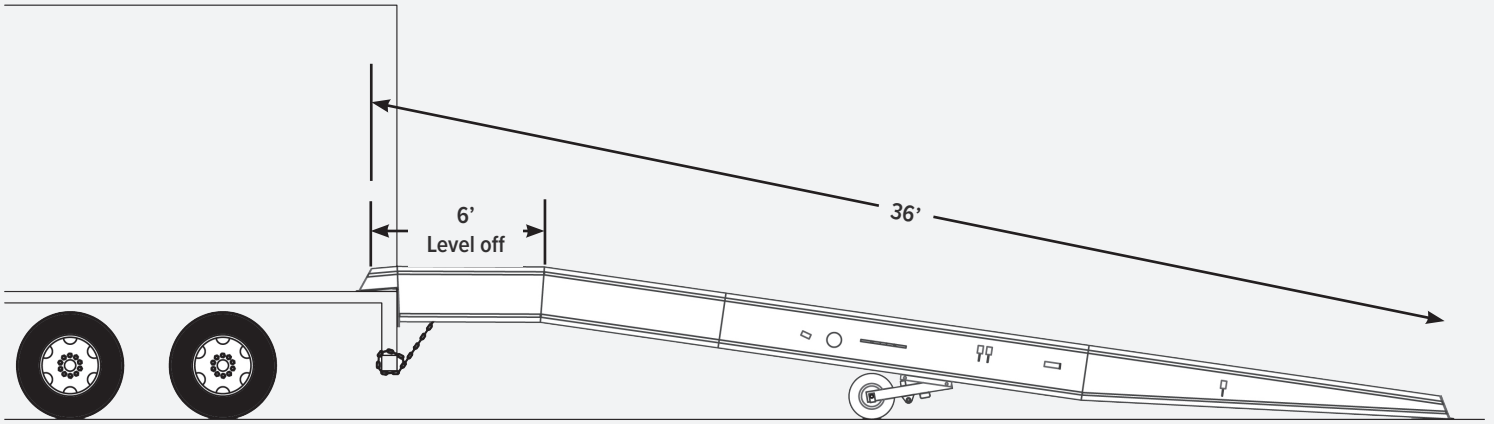

Note: 48-52" typical truck bed equals ramp grade of  $\pm 14\%$

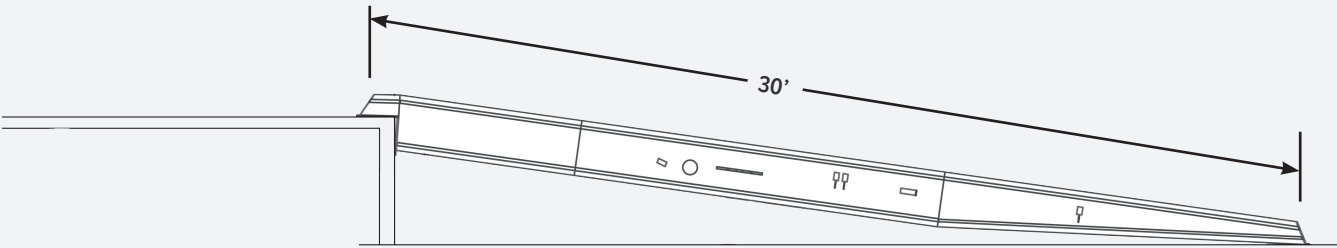

Model	Overall Width	Inside Width	Length	Lip Section	Capacity
YD 70 30	70"	64"	30'	15"	16,000 lbs
YD 84 30	84"	78"	30'	15"	20,000 lbs
YD 70 36	70"	64"	36'	15"	25,000 lbs
YD 84 36	84"	78"	36'	15"	30,000 lbs
Other Size					

Custom length and width are available.

\* Note 36' units include 6' level-off section

## Order Specifications

### Required Information

CUSTOMER	
JOB	
LOCATION	
NUMBER OF UNITS	
MODEL	
SIZE	
REPRESENTED BY	
SALES REP	

### Certified for Construction

BY	
DATE	
COMPANY	
CITY & STATE	
VOLTAGE / PHASE	
DRAWING #	