

UniChock Wheel-Based Vehicle Restraint

Specification Sheet & Submittal



Storage Bracket



Inside Signage

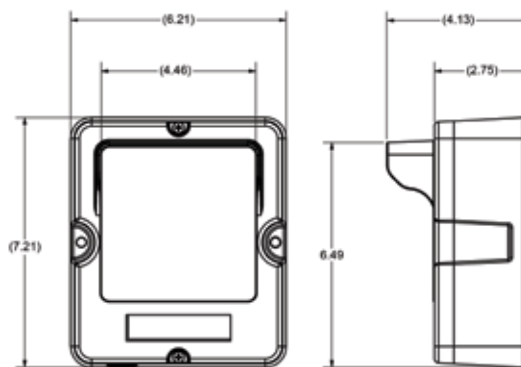

OSLA (Outside Light Assembly)

Outside Signage

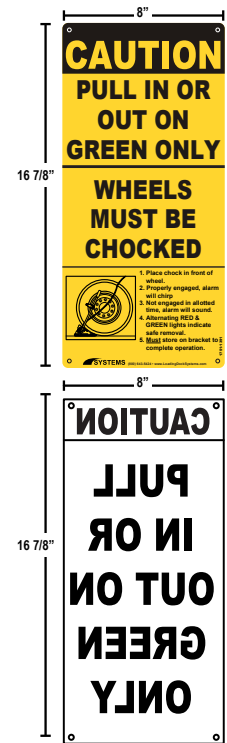

Standard Features

Universal wheel chock with light communication system	Aluminum for strength and lightweight
Audible alerts to ensure safe use and storage	Zinc-plated steel teeth and storage bracket
Interior messages for the position of the chock	Replaceable teeth for overall longevity
iDock® Alert with dynamic message display	iDock 2.0 Controls connected online with optional myQ® Enterprise
Strong grip to limit sliding	Designed and manufactured in the USA

General Description

The McGuire® UniChock™ is a wheel-based trailer restraint with advanced light communication and available as a standalone unit or integrated with other dock equipment. Universally effective in most conditions, the unit helps prevent unexpected trailer departure or movement from the loading dock during the loading process. The UniChock vehicle restraint features unique zinc plated traction teeth, inside iDock control panel, exterior communication lights and instructional signs.

Exterior Lights

Low profile, traffic style, red, and green LED lights are standard for communication to truck driver. A set of caution signs warns truck driver to “Back In or Pull Out On Green Light Only”.



Construction

The restraint unit is durable and light weight aluminum with a powder-coat finish. The traction teeth and storage bracket are zinc-plated steel. Wired sensors are installed in the restraint unit and the storage bracket. The control panel is NEMA 4X with all components, connections and wiring UL listed and/or recognized. Panels are built in-house in a UL-approved control panel shop.

Operation

Once a trailer is fully backed and parked in position against the dock bumpers, the yellow UniChock is removed from the storage bracket and placed under the front of one of the trailer's back tires. This will sound an audible indicator and display a message on the iDock Controller that the unit is in a safe position. The dock attendant can then proceed to open the door and deploy the leveler.

Electrical

The UniChock vehicle restraint is available as a stand alone unit or combined electronically in a single integrated control panel with your dock leveler selection. Interior and exterior 12-volt LED lights are powered by an integral transformer located in the control panel. Electrical control panel is a NEMA 4X enclosure.



Please Note: Unless specifically noted on quotation, all electrical requirements, including mounting of control box, outside lights and signs, are the responsibility of others.

Warranty

All UniChock vehicle restraints feature a full one (1) year base warranty on all structural, mechanical and electrical parts, including freight and labor charges in accordance with Systems, LLC's Standard Warranty Policy. Systems, LLC warrants all components to be free of defects in materials and workmanship, under normal use, during the warranty period. This base warranty period begins upon the completion of installation or the sixtieth (60th) day after shipment, whichever is earlier.

Order Specifications

Optional Equipment

Check Options Desired

- Integrated Control Panel
- Audible Alarm
- Restraint Engaged Interlock with Leveler
- Restraint Engaged Interlock with Door
- 90° storage base
- iDock 1.0 Controller (see 1.0 literature)
- Special NEMA _____ Enclosure
- Other _____

*Options must also be selected on the iDock Controls Spec Sheet

Required Information

CUSTOMER	_____
JOB	_____
LOCATION	_____
NUMBER OF UNITS	_____
MODEL	_____
SIZE	_____
REPRESENTED BY	_____
SALES REP	_____

Certified for Construction

BY _____

DATE _____

COMPANY _____

CITY & STATE _____

DRAWING # _____