

Pit Detail for Autodok H and HP Series Hydraulic

Set 3/4" conduit and recessed weatherproof 4" x 4" junction box with gasketed cover (by others) before concrete pour.

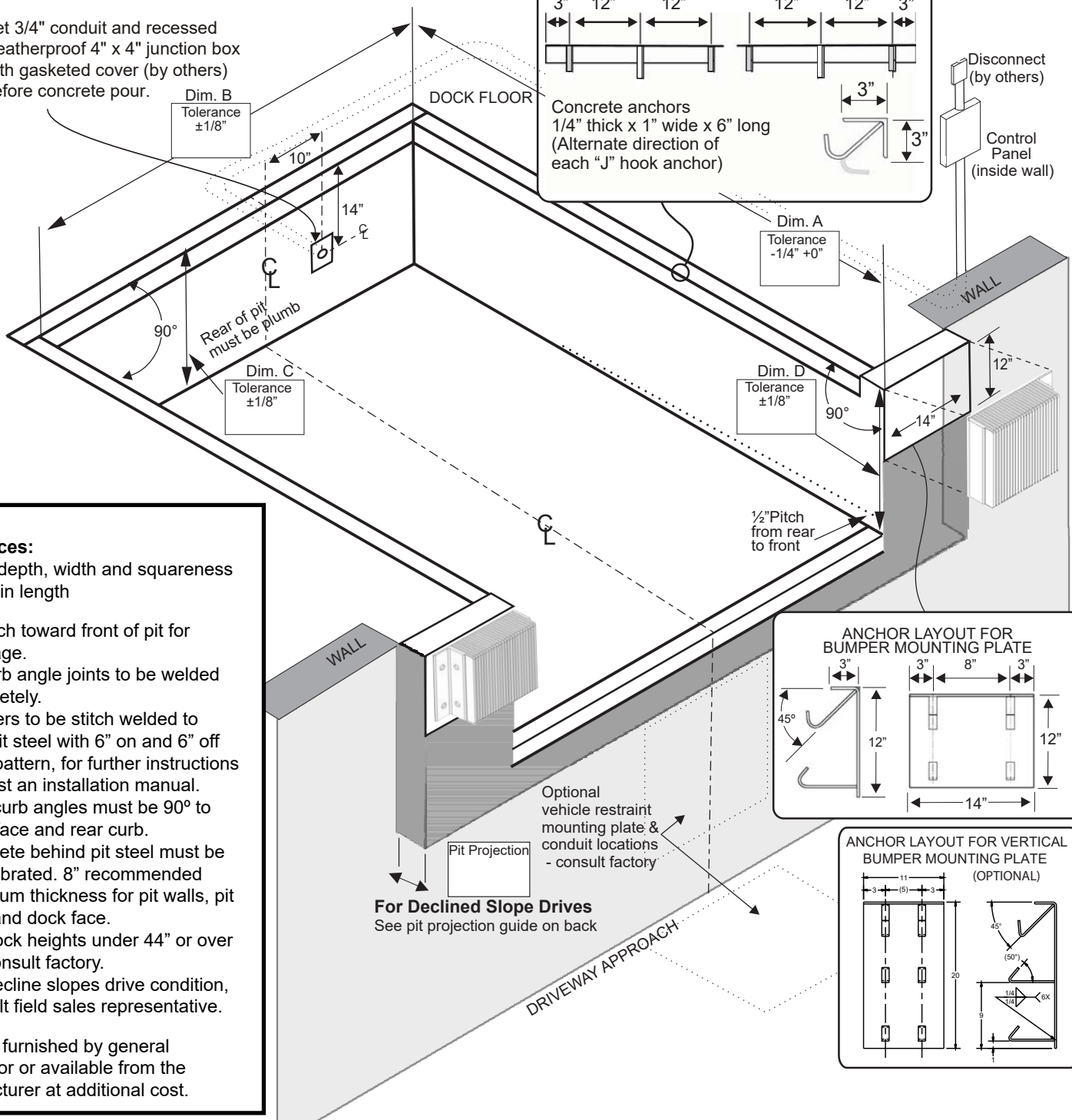

Note:

Tolerances:

$\pm 1/8"$ in depth, width and squareness
 $-1/4" +0$ in length

- 1/2" pitch toward front of pit for drainage.
- All curb angle joints to be welded completely.
- Levelers to be stitch welded to rear pit steel with 6" on and 6" off weld pattern, for further instructions request an installation manual.
- Side curb angles must be 90° to dock face and rear curb.
- Concrete behind pit steel must be well vibrated. 8" recommended minimum thickness for pit walls, pit floor and dock face.
- For dock heights under 44" or over 52" consult factory.
- For decline slopes drive condition, consult field sales representative.

Pit steel furnished by general contractor or available from the manufacturer at additional cost.

Customer:	Certified For Construction
Job:	By:
Location:	Date:
Qty:	Company:
Model/Size:	City & State:
Capacity:	Voltage/Phase:
Represented By:	Drawing#:
Sales Representative:	

Pit dimensional tolerances are $\pm 1/8$ " depth, width and squareness. $-1/4 +0$ " in length.
 McGuire/Systems, LLC assume no liability for deviations beyond this tolerance.

Dimensions below are for H & HP series hydraulic pit style levelers.								
	Contractors Bill of Material				Nominal Pit Dimensions			
	Curb Angles 1/4" x 3" x 3"			Mounting Plates 1/4" Thick	Dim. "A" Length	Dim. "B" Width	Dim. "C" Depth (rear)	*Dim. "D" Depth (Front)
	Front (Qty 1)	Rear (Qty 1)	Side (Qty 2)	Bumper Plates (Qty 2)				
6' x 6'	74"	80"	60"	3" x 12" x 14"	63"	74"	19 1/2"	20"
6.5' x 6'	80"	86"	60"	3" x 12" x 14"	63"	80"	19 1/2"	20"
7' x 6'	85"	91"	60"	3" x 12" x 14"	63"	85"	19 1/2"	20"
6' x 8'	74"	80"	84"	3" x 12" x 14"	87"	74"	19 1/2"	20"
6.5' x 8'	80"	86"	84"	3" x 12" x 14"	87"	80"	19 1/2"	20"
7' x 8'	85"	91"	84"	3" x 12" x 14"	87"	85"	19 1/2"	20"
6' x 10'	74"	80"	108"	3" x 12" x 14"	111"	74"	23 1/2"	24"
6.5' x 10'	80"	86"	108"	3" x 12" x 14"	111"	80"	23 1/2"	24"
7' x 10'	85"	91"	108"	3" x 12" x 14"	111"	85"	23 1/2"	24"
6' x 12'	74"	80"	132"	3" x 12" x 14"	135"	74"	23 1/2"	24"
6.5' x 12'	80"	86"	132"	3" x 12" x 14"	135"	80"	23 1/2"	24"
7' x 12'	85"	91"	132"	3" x 12" x 14"	135"	85"	23 1/2"	24"

**Levelers with 75,000 CIR or greater require a 24" deep pit.*

Optional Bumper Plates - in lieu of above

- 3" x 11" wide x 20" high (Qty 2)
- 3" x 11" wide x 24" high (Qty 2)
- Other Bumper Embed _____ (Qty 2)

Pit Projection Guide for Decline Slope Driveways

Percentage of Grade = $\frac{\text{Rise of Driveway}}{\text{Driveway Length}}$	% of Driveway Grade	0%	1%	2%	3%	4%	5%	6%	7%	8%	9%	10%
		Pit Projection *Excludes Bumper Projection	0"	3"	4"	5"	6"	7"	8"	9"	10"	11"

Note: Projection of pit may require modifications to seals and shelters.
 Coordinate with supplier if required.

Bumper Layout

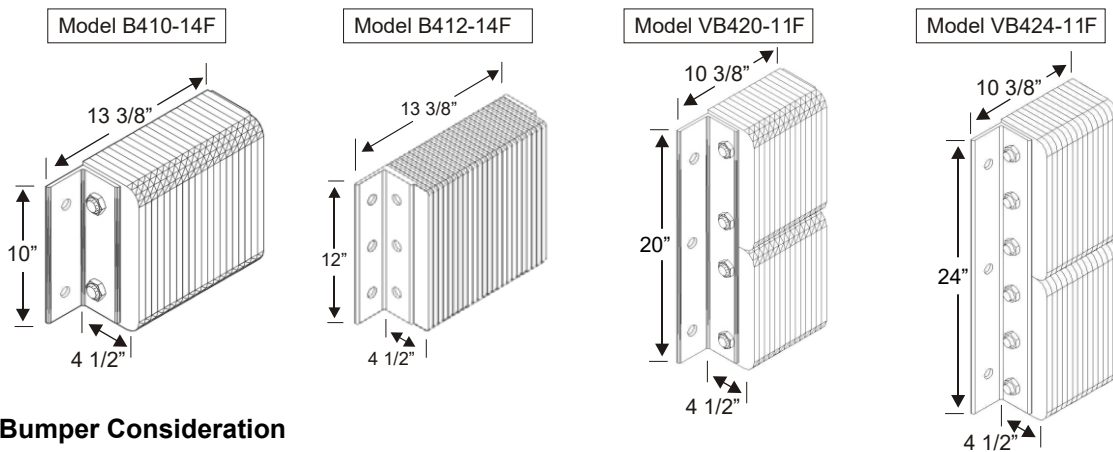

Bumper Consideration

- 2 Model B410-14F laminated bumpers **Standard on H & HP**
- Optional - 6" Projection
- Optional - Steel Face
- 2 Model B412-14F laminated bumpers
- Optional - 6" Projection
- Optional - Steel Face
- 2 Model VB420-11F laminated bumpers
- Optional - 6" Projection
- Optional - Steel Face
- 2 Model VB424-11F laminated bumpers
- Optional - 6" Projection
- Optional - Steel Face
- Other Bumper: _____

A continuing product improvement process is in effect at Systems, LLC. We reserve the right to make product changes without prior notice.

McGuire • Division of Systems, LLC • W194 N11481 McCormick Dr. • Germantown, WI 53022
 Phone: (800) 643-5424 • Email: sales@wbMcGuire.com • www.wbMcGuire.com