

Leveler Stored Sensor Installation

The Leveler Stored (L.S.) sensor is optional on most levelers. This feature is commonly used to interlock equipment and establish a safe sequence of operation. It can also report data to the iDock controller.

This sensor is available as a factory option or it can be installed using a retrofit kit. The instructions below will cover the retrofit kit installation.

DANGER

Make sure that the power source has been locked out and tagged according to OSHA regulations and approved local electrical codes.

DANGER

Unless the dock leveler is equipped with a tethered remote, two people are required to engage the maintenance prop: one person to operate the unit, the other person to engage the maintenance prop.

In addition, it is recommended and good safety practice to use an additional means to support the dock platform and lip anytime when physically working in front of or under the dock leveler. This additional means may include, but is not limited to a boom truck, fork truck, stabilizing bar or equivalent.

WARNING

Always post safety warnings and barricade the work area at dock level and ground level to prevent unauthorized use of the dock leveler before installation is complete.

A hard hat or other applicable head protection should always be worn when working under or around a dock leveler.

Always stand clear of platform lip when working in front of the dock leveler.

CAUTION

All electrical work — including the installation of the disconnect panel, control panel, and final connections to the pit junction box — must be performed by a certified electrician and conform to all local and applicable national codes.

Dock Leveler Precautions

When working with electrical or electronic controls, make sure that the power source has been tagged (A) and locked out (B) according to OSHA regulations* and approved local electrical codes (see Figure 1).

Whenever maintenance is to be performed under the dock leveler platform, support the platform with maintenance prop (C). Position the maintenance prop behind front header plate (D) while staying clear of the lip plate. The lip plate can fold down after the platform has rested on the maintenance prop. Lock the maintenance prop in the service (upright) position using an OSHA approved lockout device* (B) and tag out device* (A). See Figures 2 and 3.

Only the person servicing the equipment should have the capability to remove the lockout devices. The tag out devices* must inform that repairs are in process and clearly state who is responsible for the lockout condition.

L.S. Sensor Retrofit Installation

1. Verify that the shipping plate (E) has been removed from the leveler frame. See Figure 4. If the plate remains installed, remove it by cutting the plate on both sides. Two angles should remain at the front of the frame (F).
 2. Select a suitable location on the platform header (D) for the mounting bracket (G). Its location should provide a route to the pit junction box for electrical connections and it should not interfere with platform components, the frame, or the pit floor.
- Note:** The bracket should clear the steel frame angles to avoid false detection of the lip plate, when the platform is in the below dock position (H).
3. Clamp the bracket to the header (D) at the chosen mounting location. Bracket holes should be 1-1/8" from the bottom of the header (J). Make sure the holes will not interfere with structural members.

4. Using the bracket as a template, drill two 1/8" pilot holes. Distance between pilot hole centers is one inch (K).
5. Secure bracket to header using the included self-tapping screws.

Instructions continued on page 24.



Figure 1

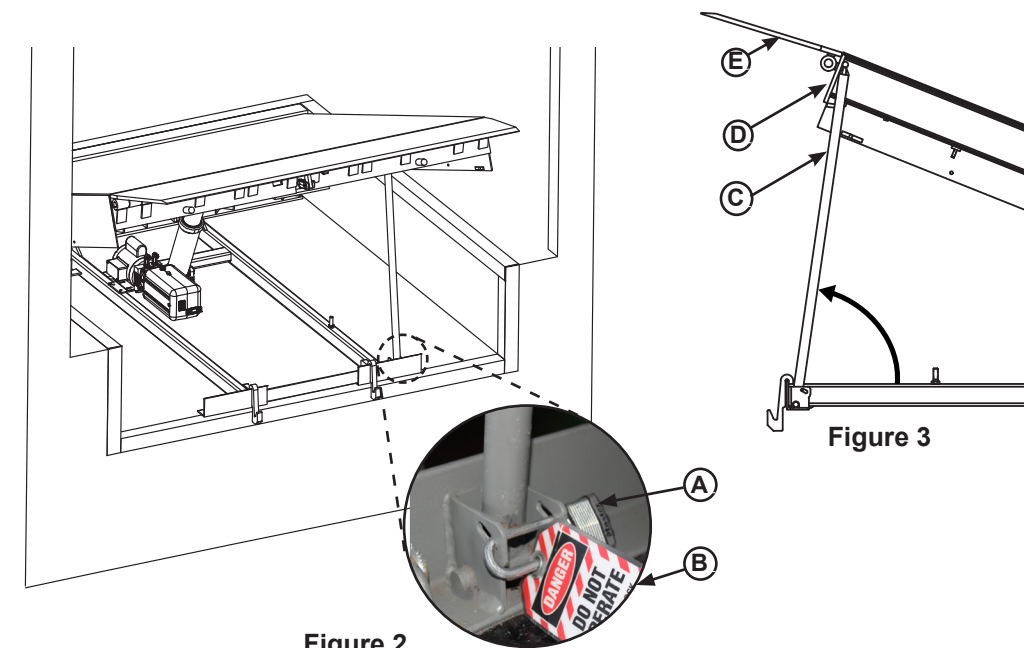

Figure 2

A — Lock Out Device C — Maintenance Prop E — Lip plate
B — Tag Out D — Header plate

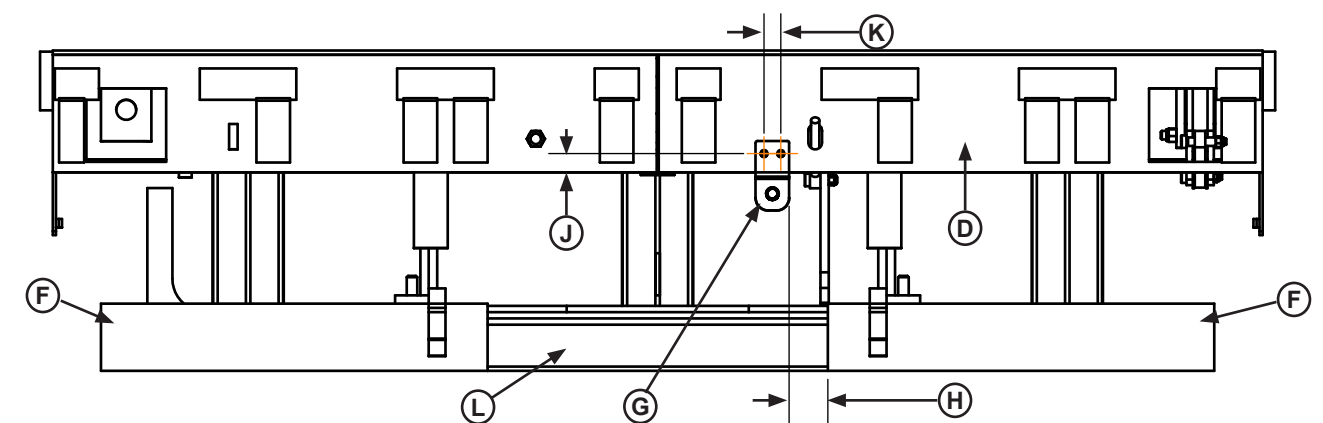

Figure 4

A — Tag Out Device D — Header G — Mounting Bracket K — Bracket Hole Spacing
B — Lock Out Device E — Lip Plate H — Steel Angle Clearance L — Shipping Plate
C — Maintenance Prop F — Front Angles J — Bracket Hole Distance

Leveler Stored Sensor Installation (Continued)

Electrical Connections

1. Install the photosensor (A) into the mounting bracket (B) using the plastic sensor nuts. Make sure that the sensor will not interfere with the lip plate (C) or frame (D), or the sensor could be damaged.
2. Verify the cable's path to the junction box (F) at the rear of the pit. See **Figure 6**. Evenly distribute the included cable tie mounting bases on the platform beam (G) next to the cable's path.

Note: Clean the beam before attaching mounting bases to ensure proper adhesion.

3. Secure the cable to the mounting bases using the included cable ties.
 - Red/ Black wire: connect to terminal block 11.
 - Red/ White wire: connect to terminal block 2.
 - Red wire: connect to H.V. Input 1 on the terminal board. Terminal number varies based on board size:
 - Small terminal board: Terminal #15
 - Large terminal board: Terminal #23
 - Green/ Yellow wire: not connected.
4. Connect the cable to the iDock controller using the connections referenced in **Figure 7**.

Small Terminal Board

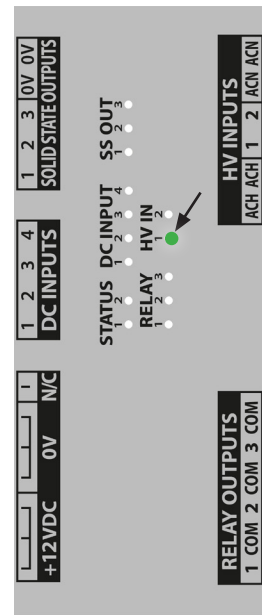

Large Terminal Board

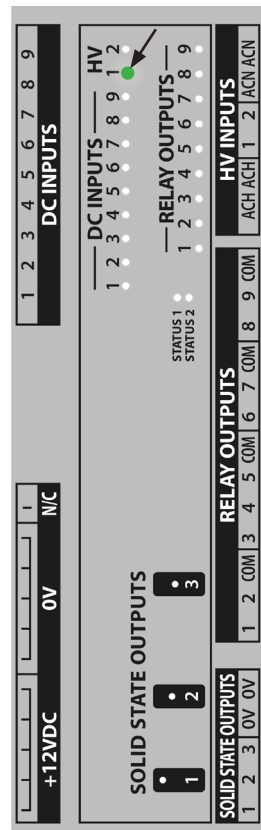

Testing Operation

1. If the sensor was installed as a retrofit, and not with the original loading dock equipment installation, make sure the iDock System Configuration and Firmware have been updated.
2. After the wiring connections have been made, safely energize the equipment and position the leveler on its maintenance prop.
3. With the power on and the lip folded, the green and amber LED's should be illuminated. This indicates that the sensor is powered on and is seeing it's target. See **Figure 8**.
4. When the lip is not completely folded, only the green LED is illuminated. This indicates the sensor is powered on, but is not sensing a target. See **Figure 8**.
5. Monitoring the terminal board in the iDock controller, can also indicate if the sensor is working correctly. HV Input #1 should illuminate when the sensor is seeing the lip plate.

6. If necessary, adjust the sensor position in the bracket by loosening the plastic sensor nuts to reposition the sensor. Adjust the sensor until it only reads the lip plate while the lip is folded fully, and in the lip keepers. See **Figure 5**.
7. Verify that the message display shows the message below:



8. If the equipment is operating correctly, based on steps 1-4 above, the installation is complete. If you need assistance with the installation, contact Systems Technical Services.

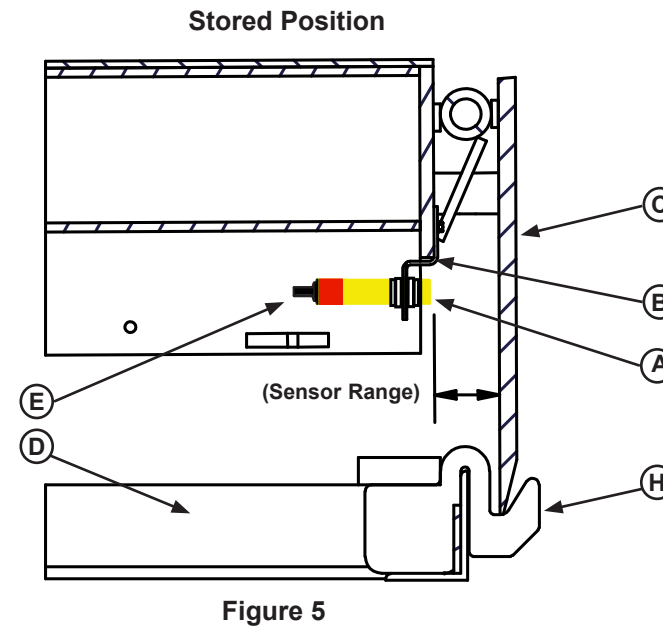

A— Photosensor C — Lip Plate
B — Mounting Bracket D— Frame

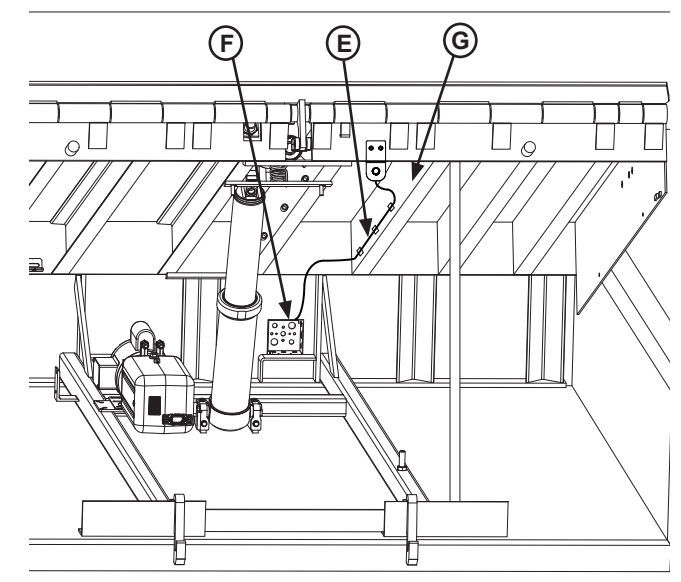

E— Cable G—Beam
F—Pit J-Box H—Lip Keeper

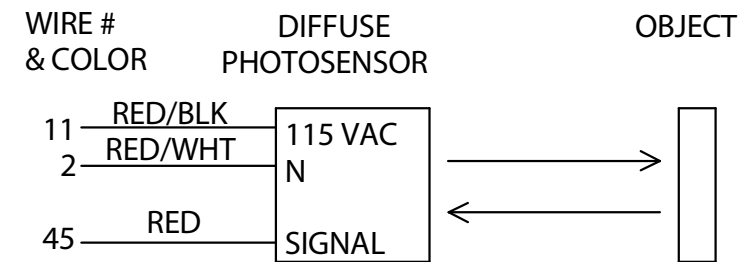
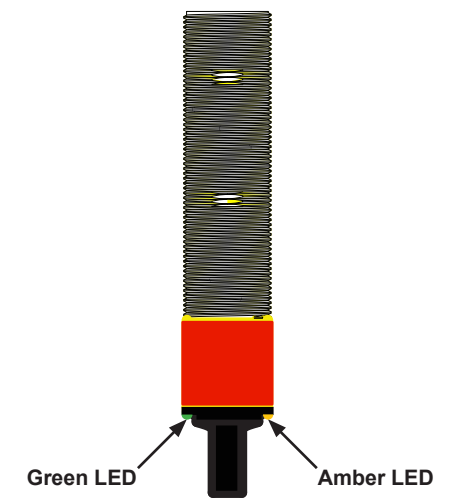

Figure 7



Green - Powered on
Amber - Sensing target
Flashing Amber - Partial Signal

Figure 8