

TS103L
CURTAIN HEAD
L PAD DOCK SEAL

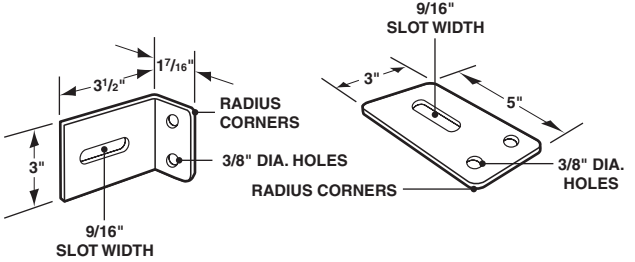

ANGLE AND FLAT MOUNTING BRACKETS

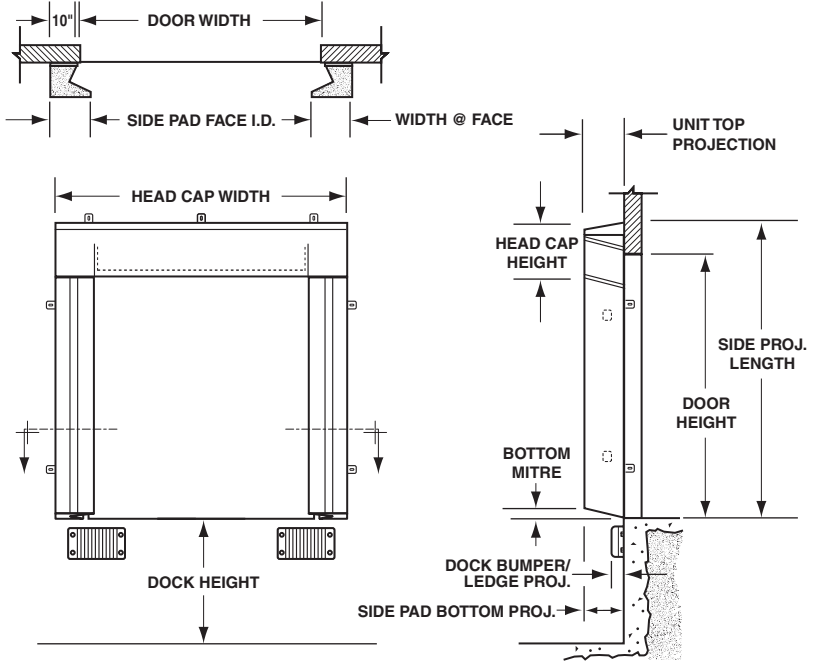
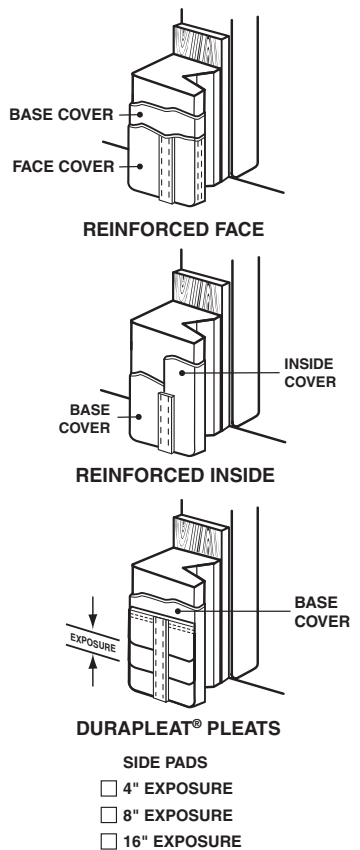
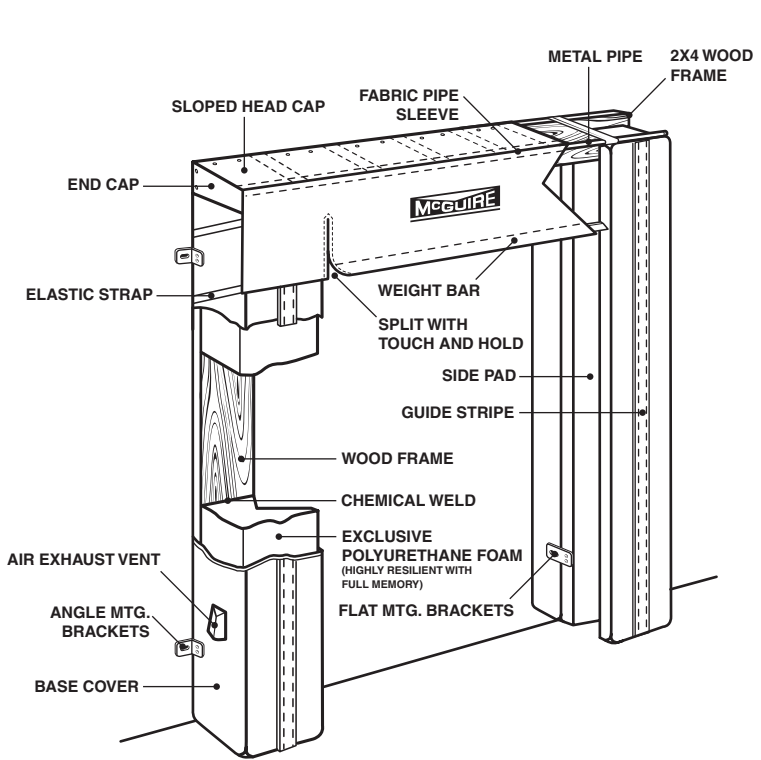
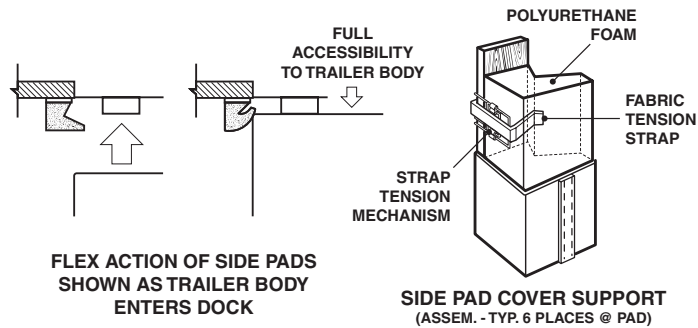

HEAD CAP DATA

___ WIDTH
___ TOTAL PROJECTION
___ VERTICAL DROP
___ BASE FABRIC
___ COLOR

END FACE REINFORCEMENT
___ FABRIC
___ COLOR

DURALPEAT® ENDS
___ FABRIC
___ COLOR
___ " PLEAT EXPOSURE

FRONT VERTICAL SPLITS
___ "E" SPLIT HEIGHT (C-6"= MAX. SPLIT)

TOUCH AND HOLD ATTACHMENT

ROPE/PULLEY SYSTEM

SIDE PAD DATA

___ LENGTH AT REAR
___ WIDTH AT REAR
___ WIDTH AT FACE
___ TOTAL PROJ. AT TOP
___ TOTAL PROJ. AT BOTTOM
___ SIDE PAD FACE I.D.
___ BASE FABRIC
___ COLOR

BLOCKOUT (IF REQUIRED)
PROJ: ___ TOP ___ BOTTOM
___ FABRIC
___ COLOR

FACE REINFORCEMENT
___ FABRIC
___ COLOR

INSIDE EDGE REINFORCEMENT
___ FABRIC
___ COLOR

DURALPEAT® PLEATS
___ FABRIC
___ COLOR
___ "PLEAT EXPOSURE

FORMED STEEL BACK
 PAINTED GALVANIZED

NON-ROT BACK

GENERAL INFORMATION

___ DOOR WIDTH
___ DOOR HEIGHT
___ DOCK HEIGHT
___ DOCK BUMPER/LEDGE
___ COMBINED PROJECTION
___ DISTANCE BETWEEN DOORS
___ CLEARANCE ABOVE DOOR

DRIVE APPROACH: LEVEL
 DECLINE ___ " IN ___ INCLINE ___ " IN ___

FB- ___ QTY. ___ SHEET ___ OF ___

McGUIRE 205 BROADVIEW STREET • P.O. BOX 151
UPPER SANDUSKY, OH 43351
PHONE 1.800.262.1188
FAX 419.294.4980
WWW.WBMCGUIRE.COM

JOB: _____

LOCATION: _____

CONTRACTOR: _____ ARCHITECT: _____

APPROVED BY SIGNATURE: _____