



W.B. McGuire™ Company
205 Broadview Street
P.O. Box 151
Upper Sandusky, OH 43351
Phone 1.800.262.1188
Fax 419.294.4980
www.wbmcguire.com

L Pad - Curtain Head TS103L Series Dock Seals

All Models

Installation Instructions



Do not install this product unless you read and understand the Warnings and Installation Instructions contained in this manual. Failure to do so could result in serious injury or death.

LPAD - CURTAIN HEAD TS103LSERIES

Installation Instructions

CHECK FIRST:

To ensure proper measurement to accommodate the Dock Seal you are installing, check the following:

A. Check the door height and width to verify that your side pads and head curtain are properly sized.

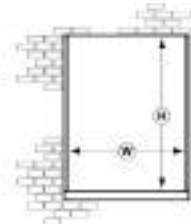

B. It is recommended that the head curtain or side pads be compressed not more than a maximum of 6"; nor more than 45% of its total projection. A minimum of 4" compression is advised to compensate for vehicles not evenly spotted against the building.

C. If the approach is not level, check to make sure the side pads taper to accommodate the angle of the truck. Also on a tapered drive, follow Step "B" for both the top and for the recommended compression.



D. Check the heights of incoming carriers that will be utilized at this door, to ensure that the head curtain is of proper elevation to accommodate the height range of these vehicles.

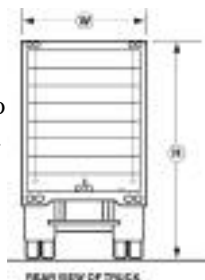

E. In 95% of installations, the inside edge of the face of the side pads should be 7'-6" I.D. If achieving the 7'-6" dimension requires extending the wood backing of the side pads into the door opening width, use the following recommendation:

Weld or anchor a structural angle the full length of the side jambs, not allowing any portion of the wood backing to be exposed into the door opening. It is appropriate to lag through the leg of the angle into the back of the wood approximately 1" from the edge of the board.

▲ WARNING

Improper lifting or attachment of seal/shelter can cause serious injury or death.

Installation requires:

- A structurally sound building wall,
- Barricades to keep people away from the area,
- Proper attachment of anchoring devices,
- Two or more people,
- A lifting device capable of lifting at least 500 lbs. at the installation angle.

If you have questions, contact your supervisor, your local McGuire™ distributor or McGuire™ at 1-800-624-8473.

INSTALLATION:

1. Mark the center of the door opening on the dock floor.
2. From this center point, measure 3'-10" in each direction to determine the position of the side pads. This should give you your 7'-8" I.D.
3. When required the "L" pads are mounted offset to the outside of the doorjamb to attain desired side pad I.D. Weld or anchor supplied offset brackets (2 per pad) into the door jamb (slotted end) allowing the end with two holes to extend 1-7/16" away from the building face. Position these brackets 1'-6" up from dock level and 1'-6" down from lintel.
4. If the side pads are flush with the door jamb, all standard mounting hardware can be utilized, which is normally: (2) 3/32"x3"x5" flat mounting brackets per pad and (2) 3/32"x3"x1-1/2"x3-1/2" angle mounting brackets per pad.

The flat brackets are secured by means of welding or anchoring into the doorjamb allowing precisely 1-7/16" projecting away from the jamb. The flat bracket should be mounted with the slotted end against the jamb, and the end with two holes extending 1-7/16" away from the jamb.

5. After the jamb brackets have been installed, mount (2) of the angle brackets on the outside of the side pads. NOTE: There are right and left side pads. To distinguish between the two, the air pockets are to be on the outside of the pad, pointing down.
6. With the appropriate side pad, predrill and mount two of the angle brackets 1'-6" from each end, using the lag screws provided. The brackets should be mounted so the slotted leg will mount against the building face. When installing the angle brackets be sure to keep the slotted leg flush with the back of the seal.
7. With the angle brackets installed, hold pad in place against the premounted jamb brackets, then predrill into the wood backing and lag secure. Mount onto the face of the building through the slot with appropriate anchors.
8. With the side pads in place, mount the head pad following the same procedures, except the air pockets point down into the opening and the head jamb brackets are mounted 1'-0" in from each end of the side jamb.
9. Caulk and fill all voids. Clean pads and hardware as required. Clear the dock area of any debris resulting from installation procedure.

SUGGESTED MOUNTING METHODS:

(Mounting anchors not included.)

Concrete or Brick Wall: Try to hit mortar joints. Use 1/2" or 3/8" x 3" expansion anchors. use through-bolt fastening if anchors will not hold, 3/8" threaded rod is recommended.

Precast Concrete: Same as above.

Metal Skin Building: Through-bolt fastening as above. Use a back-up plate (steel or wood) to support bolts or anchor through existing building horizontal and vertical structural members when possible.

NOTE: Dock Seals must have adequate bumper protection, 4" minimum.

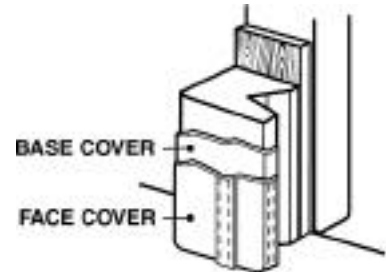

REINFORCED FACE

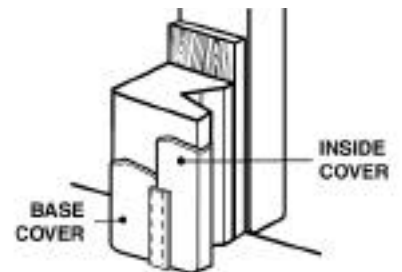

REINFORCED INSIDE

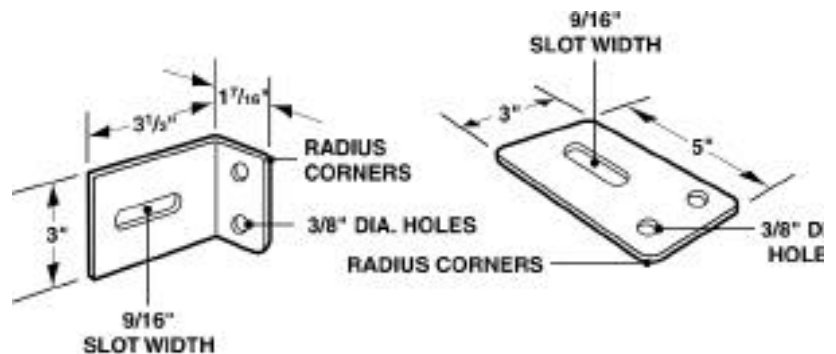
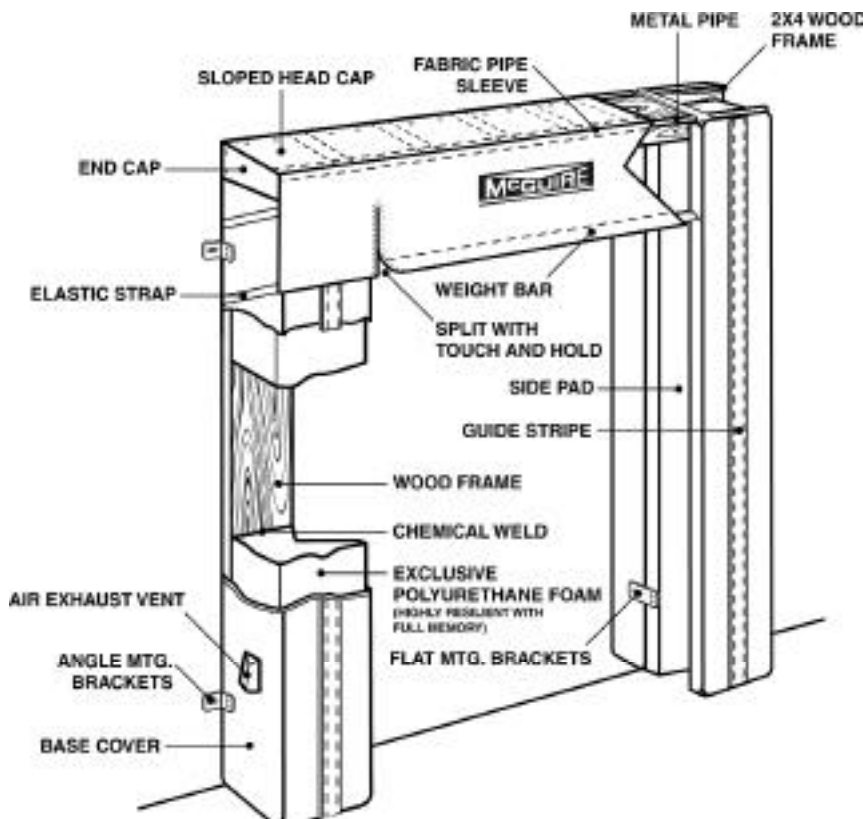

ANGLE AND FLAT MOUNTING BRACKETS

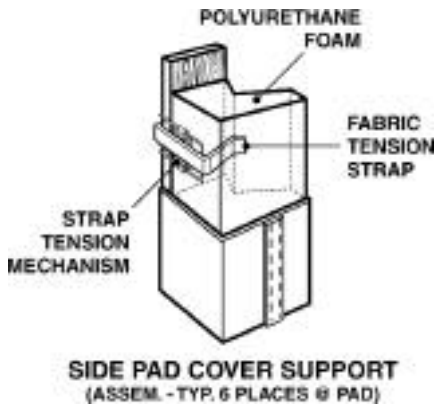

OPTIONAL DURAPLEAT®:

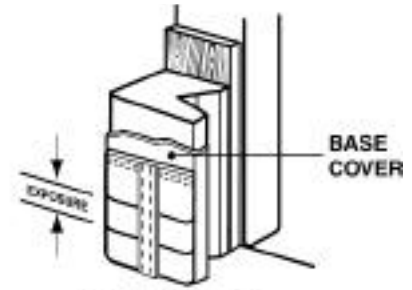

DURAPLEAT®

SIDE PADS

- 4" EXPOSURE
- 8" EXPOSURE
- 16" EXPOSURE

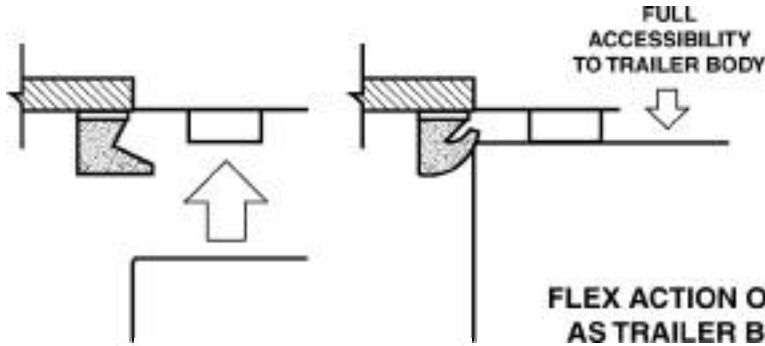

FLEX ACTION OF SIDE PADS SHOWN AS TRAILER BODY ENTERS DOCK

WARRANTY:

McGuire™ warranties extend only to the product itself.

McGuire™ DISCLAIMS all liability arising out of the workmanship, methods and materials used by the installer. WARRANTIES, whether express or implied, relating to workmanship and materials used in connection with the installation of McGuire™ products are specifically DISCLAIMED.

Note: Improper installation of anchoring devices or installation into aged or unsound concrete could result in premature product wear, product failure, or property damage.

TS103L Dock Seals are custom built for each door. installation procedures are the same for all TS103L Dock Seals regardless of size.

We have asked your local representative to present this information to you, inspect the installation, and familiarize you and your employees with proper operation of the product.

McGuire™ expressly warrants that any Dock Seal or Shelter sold by it will be free from defects in material and workmanship under normal use for a period of one (1) year from the earlier of, 1) 60 days after date of shipment, or 2) the date of installation of the Dock Seal or Shelter by the original purchaser, provided the product is properly applied and installed. In the event the Dock Seal or Shelter proves defective in material or workmanship, McGuire™ will, at its option:

1. Replace the Dock Seal or Shelter or the defective portion thereof without charge to the purchaser; or 2. Alter or repair the Dock Seal or Shelter, on site or elsewhere, without charge to the purchaser.

The warranty stated in the preceding paragraph is that expressed by McGuire™ AND IS IN LIEU OF ALL GUARANTEES AND WARRANTIES, EXPRESSED OR IMPLIED BY ANYONE OTHER THAN McGUIRE™. The warranty does not cover any failure caused by improper installation or application, abuse, or negligence. Parts requiring replacement due to damage resulting from vehicle impact, abuse or improper installation are not covered by this warranty. Seller assumes no responsibility or liability for (1) consequential damages of any kind which result from the use or misuse of the Dock Seal or Shelter, (2) damage or failure resulting from the use of unauthorized replacement parts or modification of the Dock Seal or Shelter; (3) damage resulting from the misuse of the Dock Seal or Shelter. **THERE ARE NO WARRANTIES, EXPRESSED OR IMPLIED, WHICH EXTEND BEYOND THE DESCRIPTION ON THE FACE HEREOF, AND THERE IS NO WARRANTY OF MERCHANTABILITY OR OF FITNESS FOR A PARTICULAR PURPOSE.**

McGuire™ warranties extend only to the Dock Seal or Shelter itself.

McGUIRE™ DISCLAIMS:

- ALL WARRANTIES, whether expressed or implied, relating to workmanship and materials used in connection with the installation or maintenance of the Dock Seal or Shelter.

- All liability arising out of the workmanship, methods and materials used in the installation or maintenance of the Dock Seal or Shelter.

- All liability for premature product wear, product failure, property damage or bodily injury arising from improper installation or maintenance of the Dock Seal or Shelter.