



A Division of Systems, Inc.

STOP -TITE®

Truck Restraint

Owner's/User's Manual

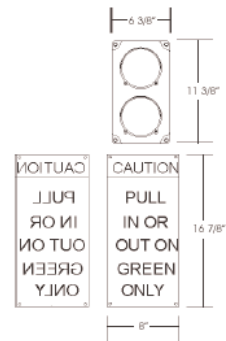
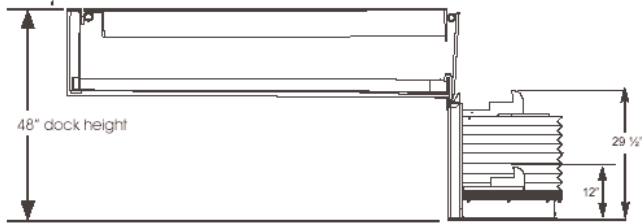

MCGUIRE • DIVISION OF SYSTEMS, INC. • W194 N11481 McCormick Drive • Germantown, WI 53022
 800.624.8473 • fax: 262.255.9399 • www.wbmcguire.com • techservices@docksystemsinc.com

Table of Contents

	Page
Safety	
Recognize Safety Information	1
General Operational Safety Precautions	1
Operational Safety Precautions	2
Maintenance Safety Precautions	4
Introduction	
General Information	5
Installation	
Install Control Panel and Wiring	6
Operation	
Operating Instructions	11
Troubleshooting	
Troubleshooting	13
Maintenance	
Periodic Maintenance	18
Parts	
Mechanical STOP-TITE® Components	20
Hydraulic STOP-TITE® Components	22
Powerpack Assembly	24
Outside Signs	26
Outside Light Assembly	27
Miscellaneous	
Customer Information	29
Warranty	Back Cover

Recognize Safety Information

Safety-Alert Symbol



The Safety-Alert Symbol identifies important safety messages on equipment, safety signs, in manuals, or elsewhere. When you see this symbol, be alert to the possibility of personal injury or death. Follow the instructions in the safety message.

DANGER

The use of the word DANGER signifies the presence of an extreme hazard or unsafe practice which will most likely result in severe injury or death.

WARNING

The use of the word WARNING signifies the presence of a serious hazard or unsafe practice which may result in serious injury or death.

CAUTION

The use of the word CAUTION signifies possible hazard or unsafe practice which could result in personal injury.

IMPORTANT

The use of the word IMPORTANT is to draw attention to a procedure that needs to be followed to prevent machine damage.

General Operational Safety Precautions



Read and understand the operating instructions and become thoroughly familiar with the equipment and its controls before operating the dock leveler or truck restraint.

Never operate a dock leveler or truck restraint while a safety device or guard is removed or disconnected.

Never remove DANGER, WARNING, or CAUTION signs or decals on the equipment unless replacing them.

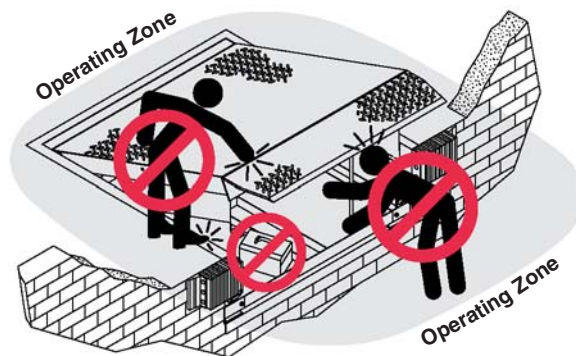

Do not start the equipment until all unauthorized personnel in the area have been warned and have moved outside the operating zone.

Remove any tools or foreign objects from the operating zone before starting.

Keep the operating zone free of obstacles that could cause a person to trip or fall.

SAFETY

Operational Safety Precautions



Learn the safe way to operate this equipment. Read and understand the manufacturer's instructions. If you have any questions, ask your supervisor.

DANGER



Stay clear of dock leveling device when freight carrier is entering or leaving area.



Do not move or use the dock leveling device if anyone is under or in front of it.



Keep hands and feet clear of pinch points. Avoid putting any part of your body near moving parts.

WARNING



Chock/restrain all freight carriers. Never remove the wheel chocks until loading or unloading is finished and truck driver has been given permission to drive away.



Do not use a broken or damaged dock leveling device. Make sure proper service and maintenance procedures have been performed before using.

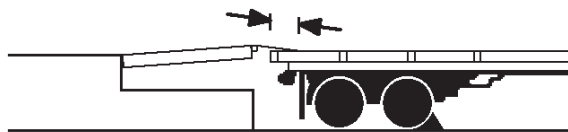

Make sure lip overlaps onto trailer at least 4 in. (102 mm).

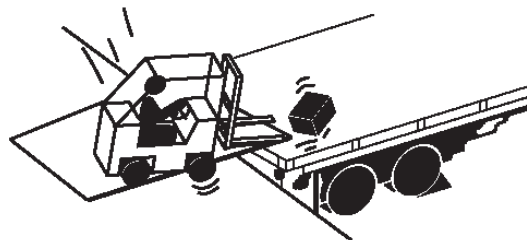

Keep a safe distance from both side edges.

⚠ WARNING

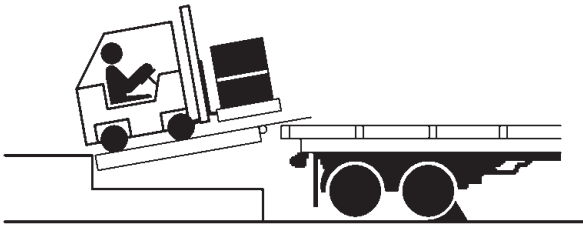

Do not use dock leveling device if freight carrier is too high or too low.



Do not overload the dock leveling device.

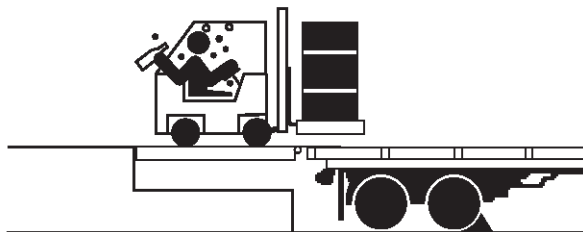

Do not operate any equipment while under the influence of alcohol or drugs.

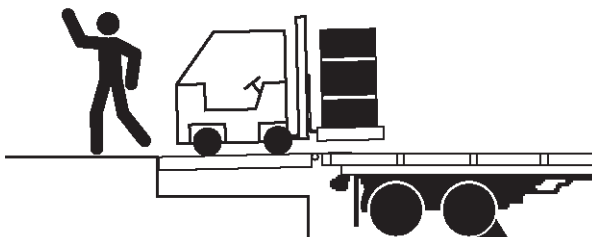

Do not leave equipment or material unattended on dock leveling device.

SAFETY

Maintenance Safety Precautions

DANGER

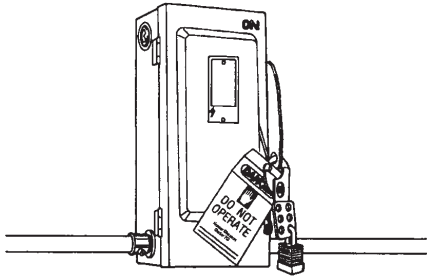

Hydraulic and electrical power must be OFF when servicing the equipment. For maximum protection, use an OSHA approved locking device to lock out all power sources. Only the person servicing the equipment should have the key to unlock the device.

CAUTION



Always post safety warnings and barricade the work area at dock level and ground level to prevent unauthorized use of the unit before maintenance is complete.

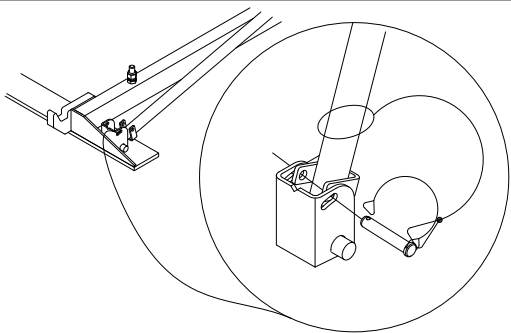

Access under the dock leveler may be required to service the truck restraint. The maintenance prop must be in the upright "service" position when working under the dock leveler. For maximum protection, use an OSHA approved locking device to lock the maintenance prop in the service position. Only the person servicing the equipment should have the key to unlock the device.

WARNING

ALWAYS disconnect electrical power source and ground wire before welding on dock leveler.

DO NOT ground welding equipment to any hydraulic or electrical components of the dock leveler. Always ground to the dock leveler frame.

Failure to follow these instructions may result in damage to dock leveler and/or serious personal injury or death.

WARNING

DO NOT grind or weld if hydraulic fluid or other flammable liquid is present on the surface to be ground or welded

DO NOT grind or weld if uncontained hydraulic fluid or other flammable liquid is present. Stray sparks can ignite spills or leaks near the work area. Always clean up the oil leaks and spills before proceeding with grinding or welding.

Always keep a fire extinguisher of the proper type nearby when grinding or welding.

Failure to follow these instructions may result in serious personal injury or death.

WARNING

ALWAYS stand clear of dock leveler lip when working in front of the dock leveler. Failure to do this may result in serious personal injury or death.

General Information

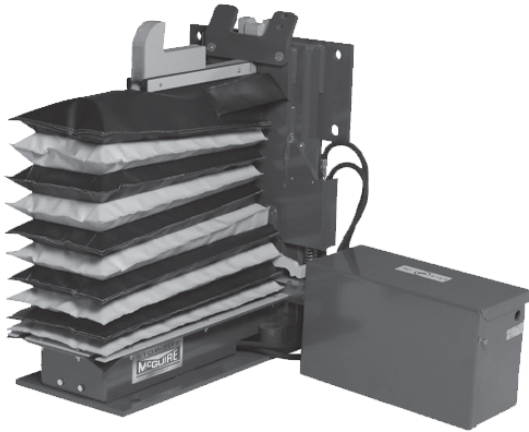

Congratulations on your choice of a McGuire truck restraint. This manual covers the STOP-TITE[®] series hydraulic dock truck restraint.

Designed by McGuire to be a marvel of simplicity and efficiency, your truck restraint, when properly installed, will provide many years of trouble-free performance with an absolute minimum of maintenance. To obtain maximum performance and longest possible use, a simple program of preventive maintenance is recommended.

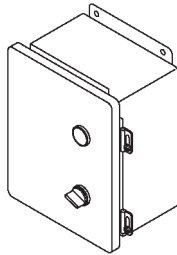

The Automatic (hydraulic) STOP-TITE[®] series truck restraint comes equipped with an electrical control panel, which allows push button operation of the truck restraint functions. Each STOP-TITE[®] dock truck restraint unit and control panel has been factory prewired and tested to ensure satisfactory operation.

To illustrate which connections are to be made in the field at installation, electrical drawings are included with each order or by contacting McGuire Technical Services.

Once again, thank you and congratulations on your purchase of a McGuire truck restraint.

STOP-TITE[®] Stock Specifications

STOP-TITE[®] truck restraints are available in the following models and options:

STOP-TITE[®] M

Mechanical STOP-TITE[®]

STOP-TITE[®] M-ML

Mechanical STOP-TITE[®]

Manual Inside and Outside Lights

STOP-TITE[®] M-AL

Mechanical STOP-TITE[®]

Automatic Inside and Outside Lights

STOP-TITE[®] A-AL

Automatic STOP-TITE[®]

Automatic Inside and Outside Lights

Note:

All STOP-TITE[®] models with the standard two level restraint hook have the same service range of 12" to 29-1/2" (304.8 mm to 749.3 mm)

With the optional Low Profile restraint hook the service range is 10" to 27-1/2" (254 mm to 698.5 mm)

Call McGuire to discuss available options to meet your specific needs.

INSTALLATION DETAILS-AUTOMATIC STOP-TITE®

STOP-TITE® Overview

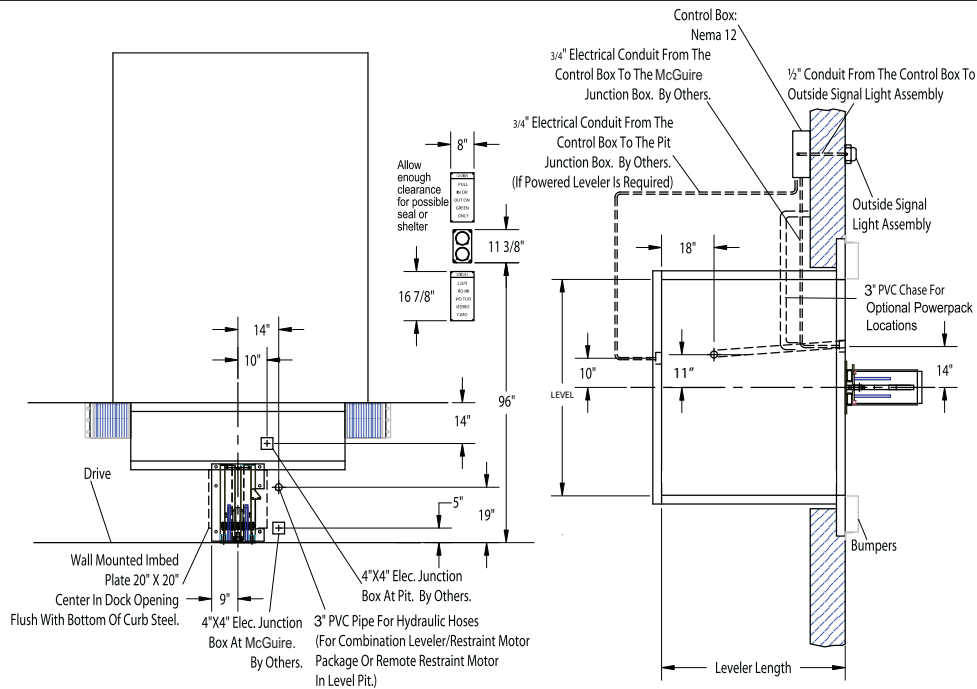

For comprehensive installation instructions of the Automatic STOP-TITE (STOP-TITE^{AAL}) read and understand the Installation and Operation Manual.

Powerpack Location Options

Coordinate powerpack location and hose length for proper placement.

Dock Face

Appropriate location when the likelihood of flooding, snow removal and damage from trailer/trucks is minimal.

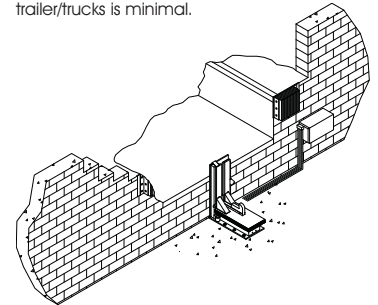

Under The Dock Leveler

When under the dock location is used, make certain to locate the powerpack where leveler will not interfere in below dock conditions. The routing of hydraulic and electrical lines from the powerpack to the restrainer are best placed through min. 3" PVC (hydraulic) and 3/4" conduit (electrical) chase during pit construction.

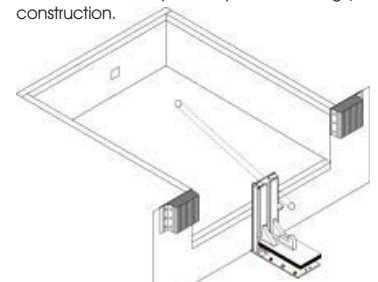

Inside Building

Locate powerpack to minimize obstruction potential. Hydraulic and electrical lines from the Powerpack to the restrainer are best placed through min. 3" PVC (hydraulic) and 3/4" (electrical) chase during pit construction.

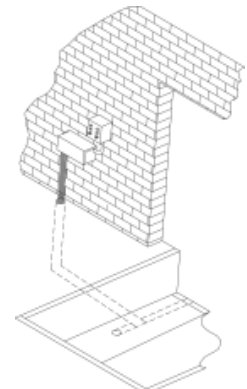

STOP-TITE^{AAL} Powerpack

Conduit, flexible or rigid, must be connected between the limit switch on the restrainer and the powerpack. Wiring to and from the restrainer must be limited to restrainer wires only. Do not run high voltage lines through the same conduit as restrainer wires. Conduit and associated hardware to complete wiring and mounting of powerpack are to be supplied by others.

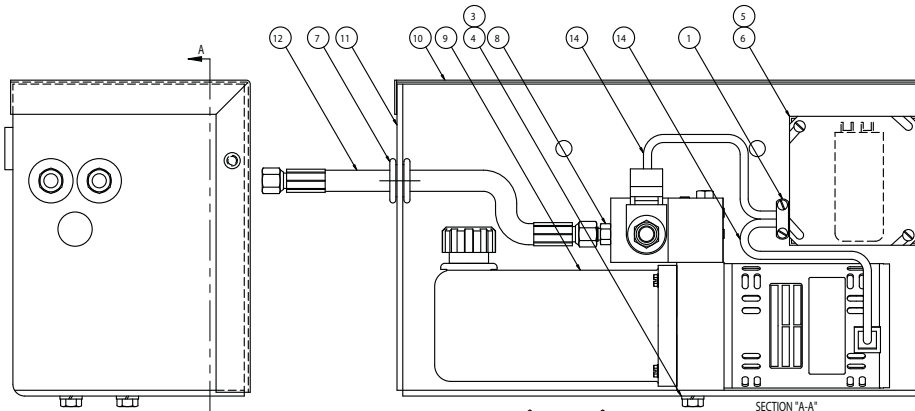

BILL OF MATERIAL				
ITEM	QTY	PART NO.	DESCRIPTION	SIZE
1	1	1431-0011	Connector - 2 Screw	3/8
2	3	1431-0086	Insulated Terminal	16-14 AWG
3	2	2101-0017	Hex Head Capscrew	3/8-16 UNC X 1
4	2	2101-0140	Lock Washer	3/8
5	1	2751-0016	Cover - J-Box	4 X 4
6	1	3051-0058	Capacitor - Motor Start	64-77MF - 330V
7	2	6431-0001	Grommet	1-3/8 OD X 3/4 ID
8	2	9301-0164	Fitting Conn Str Third	#4 ORB X #4 JIC
9	1	9395-0401	Powerpac - STOP-TITE®	1PH - 115V - 1/4 HP - 1 GPM
10	1	9391-0039	Cover - STOP-TITE®	B CAD
11	1	9393-0025	Powerpac Mounting Weldment	B CAD
12	2	9904-0097	Hyd Hose Assy - 1/4"100R1 X 24.00	#4 JIC SWIVEL BOTH ENDS
13	1	RS13-0050	Wire	16 GA RED X 5.00'
14	2	RS98-0090	Split Flex Conduit	1/4" X 9.00'

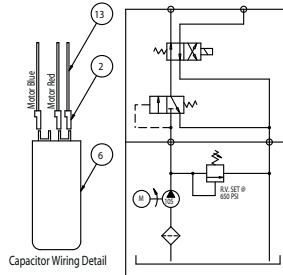

NOTE	DESCRIPTION
BC	CONNECT TO BASE END OF RELEASE CYL
BC	CONNECT TO ROD END OF RELEASE CYL

HYDRAULIC SCHEMATIC

INSTALLATION DETAILS-AUTOMATIC STOP-TITE®

Concrete Dock Face (Standard Installation)

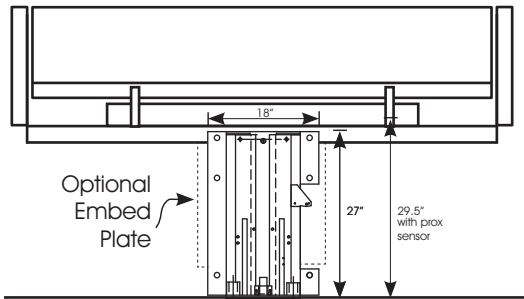

Wedge Anchors Method

Using back plate as a guide, drill six (6) holes for wedge anchors (3/4" x 5 1/4" min.) (Kit #2103-0003)

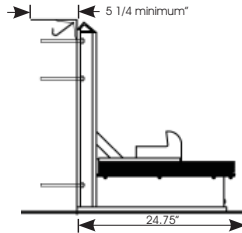

Wall Embed Method

Weld three sides of STOP-TITE back plate to the optional embed mounting plate (Part #7953-0119) with ten (10) 4" long 1/4" fillet welds.

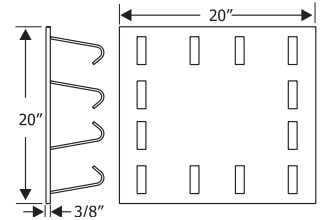

Low Pit Floor (Distance from pit floor to drive under 24")

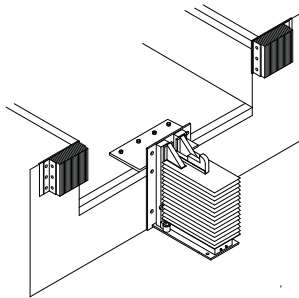

Anchor pit floor mounting plate (minimum 3/8" x 20"W x 8"D) (Part #9414-0056) with four (4) (3/4" x 5 1/4" min.) wedge anchors. Weld mounting plate to curb steel and back plate of STOP-TITE with a continuous 1/4" fillet weld. Anchor back plate of STOP-TITE to dock face with a minimum or (4) 3/4" x 5 1/4" wedge anchors (Kit#2103-0003).

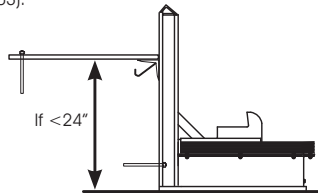

Trim or cut front frame member when necessary to allow for pit floor mounting plate.

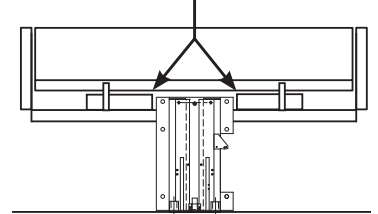

Cantilevered Dock (For bumper projection >4" or cantilevered dock or Edge-of-Dock leveler)

To determine size offset required, take total effective bumper projection (bumper size plus any cantilever) and subtract 4".

Offset Formula			
Dim. A Bumper Projection	Dim. B Cantilever		Offset
4"	+ Dim B	-4"	= Offset
6"	+ Dim B		
10"	+ Dim B		
15"	+ Dim B		

Driveway Mount

Determine offset then proceed with "Driveway Mount" instructions below.

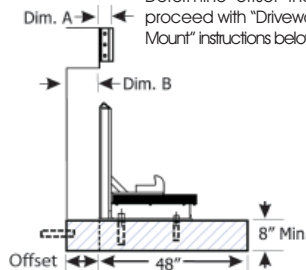

Wall Mount

For filler requirements from 1 1/2" to 7 1/2" use cantilever bracket #9414-0052 and anchor cantilever bracket to the dock face or weld to embedded mounting plate (Part #7953-0119)

For filler requirements for 8 3/4" to 13 3/4" use cantilever bracket #9414-0053 and anchor cantilever bracket to the dock face (3/4" Dia. x 5 1/4" min.) (Kit #2103-0004) or weld to embedded mounting plate (Part #9414-0052).

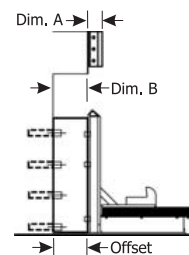

Driveway Mount (Recommended when dock face is unsuitable for STOP-TITE Mounting)

Driveway mount requires attachment to a concrete drive greater than 8" thick. For asphalt drive, pour 48" x 48" x 8" (min.) concrete pad and include six (6) 3/4" dowels into foundation wall. Then proceed with adhesive anchors or weld plate embed.

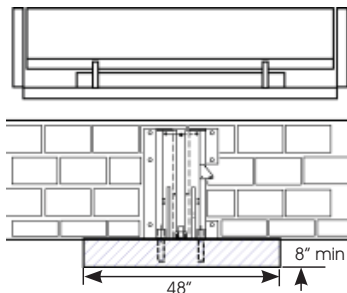

Adhesive Anchors Method

(Kit #9414-0058)

Install two (2) 1" Dia. adhesive anchors into 1-1/8" Dia. x 7" deep hole at rear of STOP-TITE.

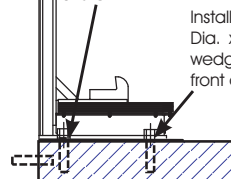

Install two (2) 3/4" Dia. x 5 1/4" min. wedge anchor at front of STOP-TITE.

Drive Embed Method

Weld Method

Properly locate and level the drive embed weld plate (Part #7953-0059) in the drive approach. Observe Cantilever conditions for proper positioning. Weld restraint to embed plate with a continuous 1/4" fillet weld.

Bolt on Method

Properly locate and level the drive embed plate (Part #9414-0057) in the drive approach. Observe cantilever conditions for proper positioning. Using the bolts included, bolt the restraint to the embed plate.

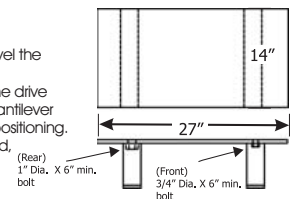

INSTALLATION DETAILS-MECHANICAL STOP-TITE®

STOP-TITE Overview

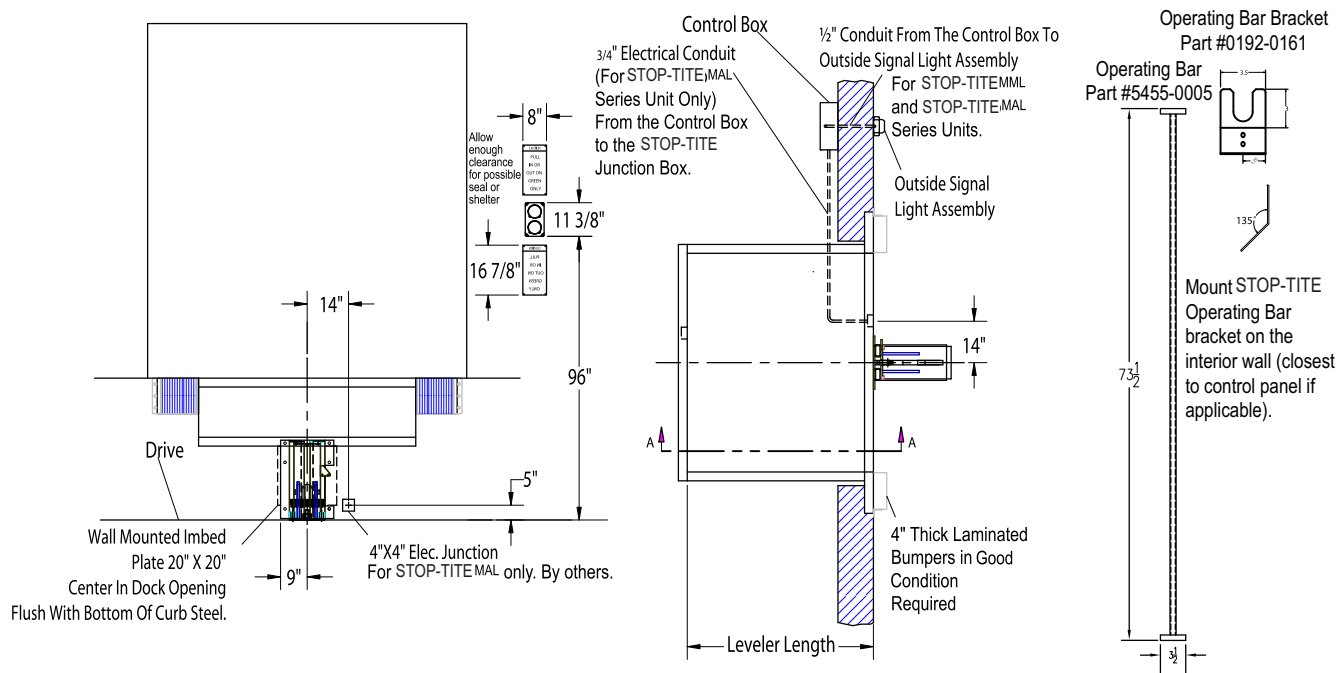

Optional Light Communication System

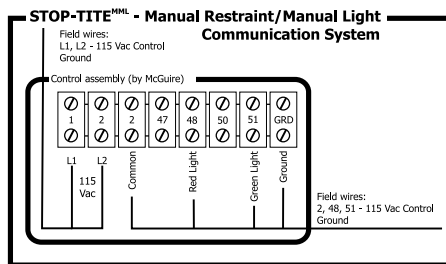
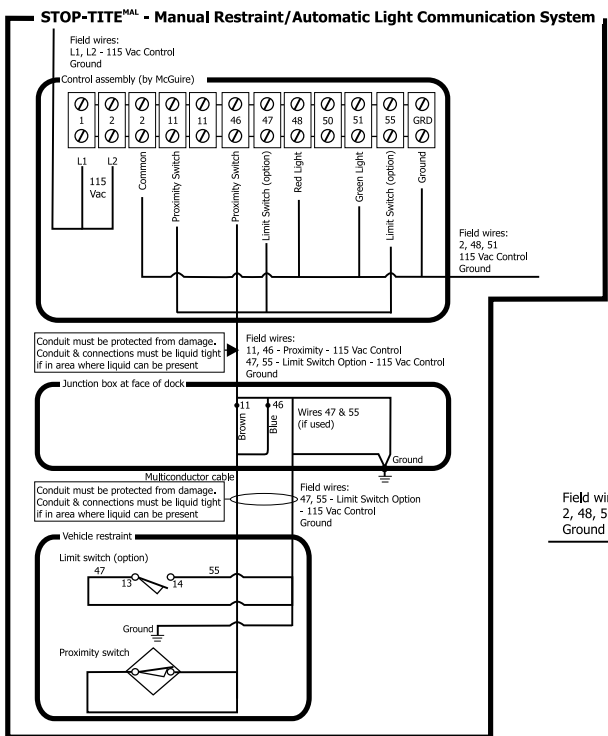

Outside signal light assembly by McGuire included with optional Light Communication Systems

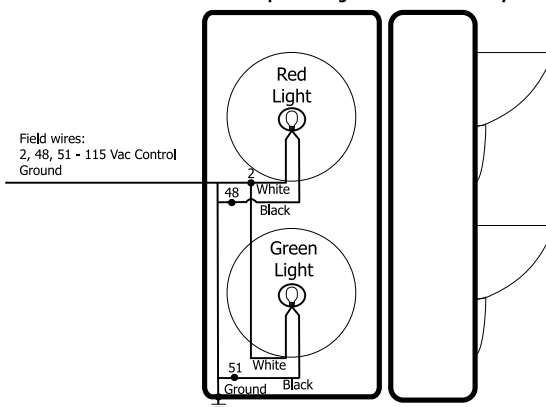

For comprehensive installation instructions of the Manual STOP-TITE (STOP-TITE^M) read and understand the Installation and Operation Manual.

INSTALLATION DETAILS-MECHANICAL STOP-TITE®

Concrete Dock Face (Standard Installation)

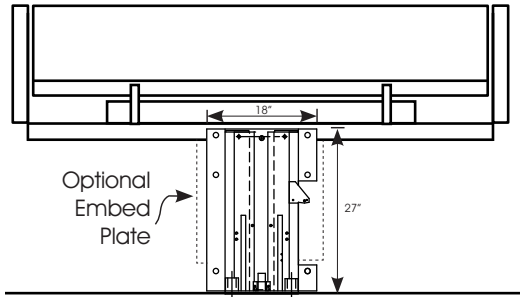

Wedge Anchors Method

Using back plate as a guide, drill six (6) holes for wedge anchors (3/4" x 5 1/4" min.) (Kit #2103-0003)

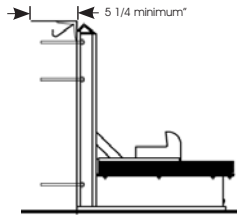

Wall Embed Method

Weld three sides of STOP-TITE back plate to the optional embed mounting plate (Part #7953-0119) with ten (10) 4" long 1/4" fillet welds.

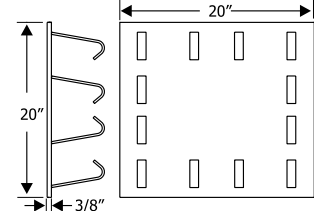

Low Pit Floor (Distance from pit floor to drive under 24")

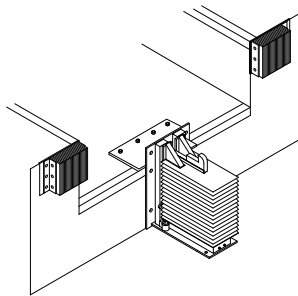

Anchor pit floor mounting plate (minimum 3/8" x 20"W x 8"D) (Part #9414-0056) with four (4) (3/4" x 5 1/4" min.) wedge anchors. Weld mounting plate to curb steel and back plate of STOP-TITE with a continuous 1/4" fillet weld. Anchor back plate of STOP-TITE to dock face with a minimum of (4) 3/4" x 5 1/4" wedge anchors (Kit#2103-0003).

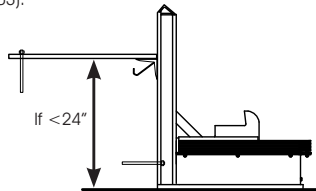

Trim or cut front frame member when necessary to allow for pit floor mounting plate.

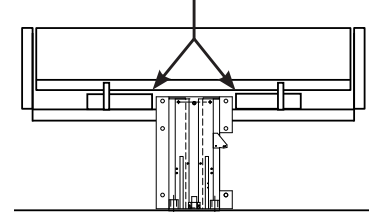

Cantilevered Dock (For bumper projection >4" or cantilevered dock or Edge-of-Dock leveler)

To determine size offset required, take total effective bumper projection (bumper size plus any cantilever) and subtract 4".

Offset Formula			Offset
Dim. A Bumper Projection	Dim. B Cantelever		
4"	+ Dim B	-4"	= Offset
6"	+ Dim B		
10"	+ Dim B		
15"	+ Dim B		

Driveway Mount

Determine offset then proceed with "Driveway Mount" instructions below.

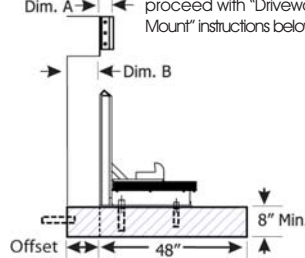

Wall Mount

For filler requirements from 1 1/2" to 7 1/2" use cantilever bracket #9414-0052 and anchor cantilever bracket to the dock face or weld to embedded mounting plate (Part #7953-0119)

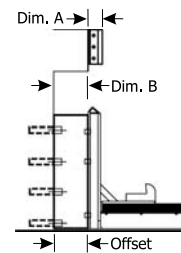

For filler requirements for 8 3/4" to 13 3/4" use cantilever bracket #9414-0053 and anchor cantilever bracket to the dock face (3/4" Dia. x 5 1/4" min.) (Kit #2103-0004) or weld to embedded mounting plate (Part #9414-0052).

Driveway Mount (Recommended when dock face is unsuitable for STOP-TITE) Mounting)

Driveway mount requires attachment to a concrete drive greater than 8" thick. For asphalt drive, pour 48" x 48" x 8" (min.) concrete pad and include six (6) 3/4" dowels into foundation wall. Then proceed with adhesive anchors or weld plate embed.

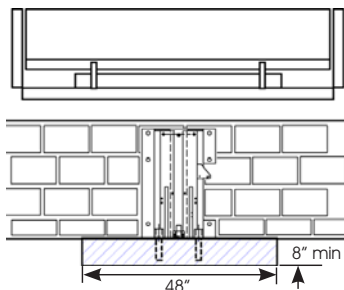

Adhesive Anchors Method (Kit #9414-0058)

Install two (2) 1" Dia. adhesive anchors into 1-1/8" Dia. x 7" deep hole at rear of STOP-TITE.

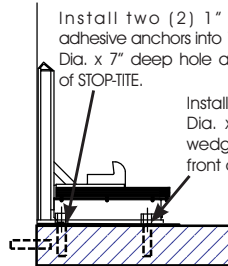

Install two (2) 3/4" Dia. x 5 1/4" min. wedge anchor at front of STOP-TITE.

Drive Embed Method

Weld Method

Properly locate and level the drive embed weld plate (Part #7953-0059) in the drive approach. Observe Cantilever conditions for proper positioning. Weld restraint to embed plate with a continuous 1/4" fillet weld.

Bolt on Method

Properly locate and level the drive embed plate (Part #9414-0057) in the drive approach. Observe cantilever conditions for proper positioning. Using the bolts included, bolt the restraint to the embed plate.

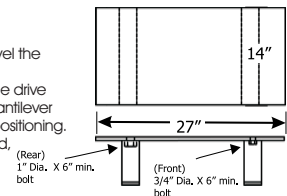

INSTALLATION

Install Control Panel and Wiring

WARNING

The electrical power must be OFF prior to electrical installation. For maximum protection, use an OSHA approved locking device to lock out all power sources. Only the person installing the equipment should have the key to unlock the power source.

Failure to follow these instructions may result in serious personal injury or death.

WARNING

DO NOT make any final electrical connections until all welding has been completed. Failure to do this may result in serious personal injury or death.

CAUTION

All electrical work—including the installation of the disconnect panel, control panel, and final connections—must be performed by a certified electrician and conform to all local and applicable national codes.

WARNING

If dock leveler is present. Always stand clear of platform lip when working in front of the dock leveler. Serious personal injury or death may result.

A—Disconnect Panel (provided by others)
B—Control Panel C—Distance, 48 in. (14 630 mm)

1. Mount the push button control panel (B) so bottom of control panel-to-dock floor distance (C) is 48 in. (1219.2 mm).
2. Install electrical disconnect panel (A) if not already installed. (Provided by others)
3. Install and connect the control wiring to the face of the building as shown in installation.
4. Connect the dock leveler power cable to the field wires in the pit junction box. Refer to the electrical drawings supplied with the dock leveler.
5. After all electrical connections in the truck restraint have been made, test the truck restraint function by following the instructions in the “Put New STOP-TITE® Restraint Into Service” section on next page.

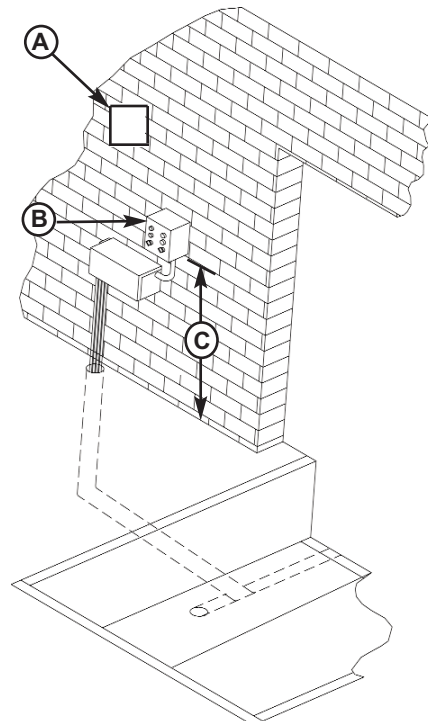
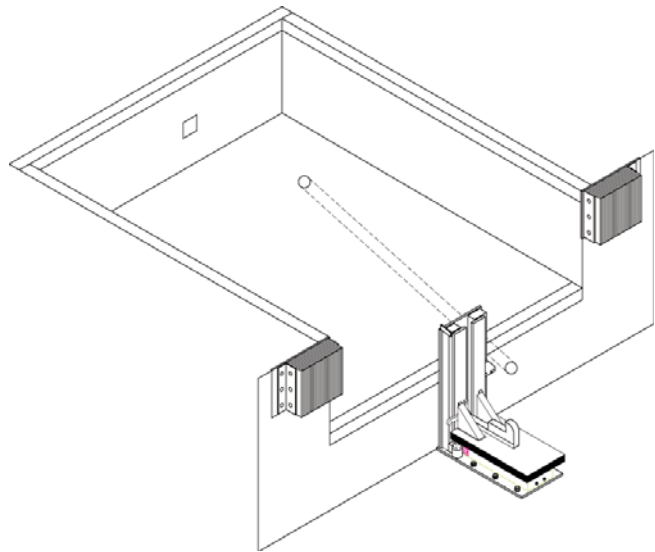
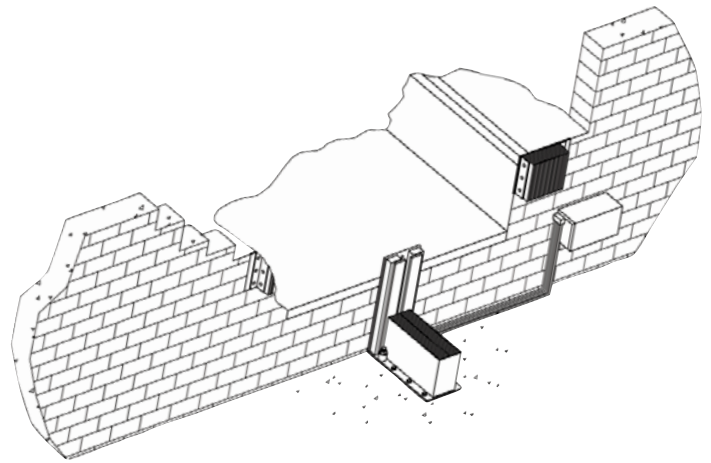

Operating Instructions

DANGER

Stay clear of dock leveler and truck restraint when freight carrier is entering or leaving dock area.

DO NOT move or use the dock leveler if anyone is under or in front of leveler.

Keep hands and feet clear of pinch points. Avoid putting any part of your body near moving parts.

Failure to follow these instructions may result in severe personal injury or death.

WARNING

Only trained personnel should operate the dock leveler and truck restraint.

DO NOT use a broken or damaged dock leveler or truck restraint. Make sure proper service and maintenance procedures have been performed on leveler before using.

Truck/trailer wheels must be chocked unless the truck restraint is used. Never remove the wheel chocks until loading/unloading is finished and truck driver has been given permission to leave.

Make sure platform lip rests on the truck/trailer bed with at least 4 in. (102 mm) of overlap.

Maintain a safe distance from side edges of leveler during the loading/unloading process.

Failure to follow these instructions may result in serious personal injury or death.

WARNING

Once the STOP-TITE[®] truck restraint has been activated, the dock attendant must visually inspect to assure that the restraint hook has properly engaged the ICC (RIG) bar. Serious personal injury or death may result.

Proper engagement occurs when the hook is able to travel vertically, contacting the bottom edge of the horizontal member of the ICC bar (RIG), without obstruction.

1. Disconnect the external lifting device and lifting brackets.
2. Remove latch shipping bolt from latch mechanism on both manual and hydraulic models. This prevents STOP-TITE[®] from raising.
3. Turn the main electrical power ON (Hydraulic Only).
4. Raise the STOP-TITE[®] truck restraint fully by pushing and holding the ENGAGE/LOCK button on Automatic/Hydraulic units or pulling latch release with the handle provided on the Mechanical STOP-TITE[®].

NOTE: The restraint weldment should raise to the top of the track, contacting the track stop.

NOTE: STOP-TITE[®] equipped with Automatic Lights should have a Green light inside and Red light outside when raised unless equipped with optional upper limit switch. A visible or audible alarm will signal the restraint weldment has reached the top of the track and may not have properly engaged the ICC bumper, if present.

5. Lower the STOP-TITE[®] truck restraint fully by pushing and holding the RELEASE/UNLOCK button. The restraint weldment should lower fully until the latch release is engaged.

NOTE: STOP-TITE[®] equipped with Automatic Lights should have a Red light inside and green light outside when the restraint weldment is stored.

6. If STOP-TITE[®] truck restraint cannot properly restrain the vehicle due to missing or defective ICC (RIG) bar advise truck driver and dock personnel. Truck/trailer must be secured against movement by other methods. For levelers interlocked with the truck restraint, turn the selector switch to Bypass to allow use of the dock leveler and proper light changes inside and outside the building (where equipped with lights).

This Page Intentionally Left Blank

Mechanical Troubleshooting







Problem	Possible Solution(s)
Restraint weldment (hook) will not raise.	<ol style="list-style-type: none">1. Check side release latch for binding, lubricate if needed.2. Check restraint body for debris.3. Check for broken extension springs.4. Check link joints for missing or bent shoulder bolts, pins or excessive wear.5. Check front pin slot under restraint weldment for damage. If trucks with lift gates back into restraint front portion of hook weldment can be bent up or down, causing slot to close and pin to bind.6. Joints are permanently lubricated bushings and should not require oiling, however, rubbing surfaces of links should be lubricated per maintenance section of this manual.
Restraint weldment (hook) will not lower.	<ol style="list-style-type: none">1. Check side release latch for binding, lubricate if needed.2. Check restraint body for debris.3. Check for broken extension springs.4. Check link joints for missing or bent shoulder bolts, pins or excessive wear.5. Check front pin slot under restraint weldment for damage. If trucks with lift gates back into restraint front portion of hook weldment can be bent up or down, causing slot to close and pin to bind.6. Joints are permanently lubricated bushings and should not require oiling, however, rubbing surfaces of links should be lubricated per maintenance section of this manual.7. Check to make sur truck has not moved forward, wedging ICC (RIG) bar against restraint hook weldment. Back truck up tight against bumper and repeat unlock procedure.

Troubleshooting

Hydraulic Troubleshooting

Problem	Possible Solution(s)
Restraint will not raise.	<ol style="list-style-type: none">1. Remove excess load from restraint. Unit is designed to raise no more than its own weight as a safety feature.2. Strainer element plugged. Remove reservoir and clean or replace strainer element.3. Hydraulic valve may be not be actuating. Locate solenoid coil. Check solenoid valve coil to confirm it is energized when raising restraint. Check solenoid valve to confirm it is closed at rest and opens when coil activated.
Restraint moves very slowly.	<ol style="list-style-type: none">1. Low hydraulic fluid. Add hydraulic fluid as needed.2. Pump by-pass set too low. Pump by-pass adjustment is internal to pump. consult factory.3. Debris in horizontal or vertical track. Clean tracks and re-test.4. Scissors pins binding. Check for rust, lubricate as needed. Check for bent weldment. Repair or replace as needed.
Restraint moves in one direction only regardless of button pushed.	<ol style="list-style-type: none">1. Four way valve stuck in either position. Locate solenoid coil. Check coil for cracks or bulging. Remove coil from solenoid valve and valve from valve block. Check solenoid valve for contaminant's and/or damage, including o-rings. Replace solenoid valve if damaged. <p>DO NOT over tighten valve in valve block or coil on valve when reinstalling. Valve torque is 15 foot lbs and coil nut is 15 inch lbs. Replace spool valve if problem persists and all other troubleshooting procedures have been performed.</p>

Electrical Troubleshooting

Problem	Possible Solution(s)				
Restraint does not raise or lower - Motor does not run, inside and outside lights do not work.	<ol style="list-style-type: none">1. No voltage at control assembly. Check voltage input.2. Blown fuse inside control assembly. Use voltmeter to test.				
<table border="1"><thead><tr><th data-bbox="183 661 829 724">IMPORTANT</th></tr></thead><tbody><tr><td data-bbox="183 724 829 976">Do not run motor when valves are removed from valve block. Do not over tighten coil on valve: 15 inch lbs max which is just over finger tight. Do not over tighten valve into block: 15 foot lbs max which is enough to compress the washer and prevent leakage.</td></tr></tbody></table>	IMPORTANT	Do not run motor when valves are removed from valve block. Do not over tighten coil on valve: 15 inch lbs max which is just over finger tight. Do not over tighten valve into block: 15 foot lbs max which is enough to compress the washer and prevent leakage.	<table border="1"><thead><tr><th data-bbox="829 451 1536 514"> WARNING</th></tr></thead><tbody><tr><td data-bbox="829 514 1536 640">Line side of fuse is always hot. Turn off main power supply before removing fuses. Attach proper lock-out / tag-out devices.</td></tr></tbody></table> <ol style="list-style-type: none">3. Defective contact block at power selector switch. Test with voltmeter.4. Defective contactor. Use voltmeter to test voltage coming in to contactor and going out of contactor when contactor is activated.5. Defective overload. Use voltmeter to test voltage coming in to contactor and going out of contactor when contactor is activated. <ol style="list-style-type: none">1. Voltage too low. Check for low voltage. Increase wire size from main electrical panel to PowerStop control panel to correct voltage drop.2. Defective capacitor. Disconnect capacitor. Test.	 WARNING	Line side of fuse is always hot. Turn off main power supply before removing fuses. Attach proper lock-out / tag-out devices.
IMPORTANT					
Do not run motor when valves are removed from valve block. Do not over tighten coil on valve: 15 inch lbs max which is just over finger tight. Do not over tighten valve into block: 15 foot lbs max which is enough to compress the washer and prevent leakage.					
 WARNING					
Line side of fuse is always hot. Turn off main power supply before removing fuses. Attach proper lock-out / tag-out devices.					
Restraint does not raise or lower-motor hums but does not run, inside and outside lights work.	<table border="1"><thead><tr><th data-bbox="829 1207 1536 1270"> CAUTION</th></tr></thead><tbody><tr><td data-bbox="829 1270 1536 1365">Discharge capacitor before attempting a capacitor test.</td></tr></tbody></table> <ol style="list-style-type: none">1. Solenoid coil not electrically energizing. Check coil for magnetism. use voltmeter to test voltage at coil.2. Solenoid valve mechanically stuck OFF. Remove valve, inspect valve and block for contaminant's. Test. Replace if necessary.	 CAUTION	Discharge capacitor before attempting a capacitor test.		
 CAUTION					
Discharge capacitor before attempting a capacitor test.					
Restraint does not raise-motor runs in pressure relief, inside and outside lights work.	<ol style="list-style-type: none">1. Defective contact block at activated pushbutton. Use voltmeter to test. <ol style="list-style-type: none">2. No voltage at motor. Use voltmeter to test voltage at motor.3. Thermal protector inside motor has tripped. Wait for protector to reset.				
Restraint does not raise-motor does not run, inside and outside lights work.	<ol style="list-style-type: none">1. Defective contact block at activated pushbutton. Use voltmeter to test. <ol style="list-style-type: none">2. No voltage at motor. Use voltmeter to test voltage at motor.3. Thermal protector inside motor has tripped. Wait for protector to reset.				

Troubleshooting

Electrical Troubleshooting Continued

Problem

Restraint does not lower-motor runs in pressure relief, inside and outside lights work.

Possible Solution(s)

1. Solenoid valve mechanically stuck ON. Remove solenoid valve from hydraulic block. Inspect block for contaminants. Test. Replace if necessary.

IMPORTANT
Do not run motor when valves are removed from valve block. Do not over tighten coil on valve: 15 inch lbs max which is just over finger tight. Do not over tighten valve into block: 15 foot lbs max which is enough to compress the washer and prevent leakage.

Restraint does not lower-motor does not run, inside and outside lights work.

1. Obstruction activating stored limit switch. Remove obstruction. Make sure limit switch operates properly and light changes on limit switch.

NOTE: If equipped with outside signal lights, holding screwdriver in front of switch and then removing screwdriver will result in lights changing.

2. Defective limit switch. Use voltmeter to test stored limit switch operation.

3. Defective control relay(s). Use voltmeter to test voltage at relays(s) coil and to test relay(s) contact operation or swap relays one at a time from known working restraint control box to determine faulty relay.

4. No voltage at motor. Use voltmeter to test voltage at motor to determine if wiring is faulty.

5. Motor faulty. Test motor with with voltmeter. Replace if necessary.

Lights do not work or lights do not work correctly-restraint raises and lowers.

1. Defective bulb. Replace.

2. Obstruction preventing activation or deactivation of stored limit switch. Remove obstruction. Test switch for proper operation.

3. Defective stored limit switch. Use voltmeter to test switch.

4. Defective control relay. Use voltmeter to test voltage at relay coil and to test relay contact operation.

5. Defective contact block(s) at light control selector (or key) switch. Test with voltmeter.

This Page Intentionally Left Blank

MAINTENANCE

Periodic Maintenance

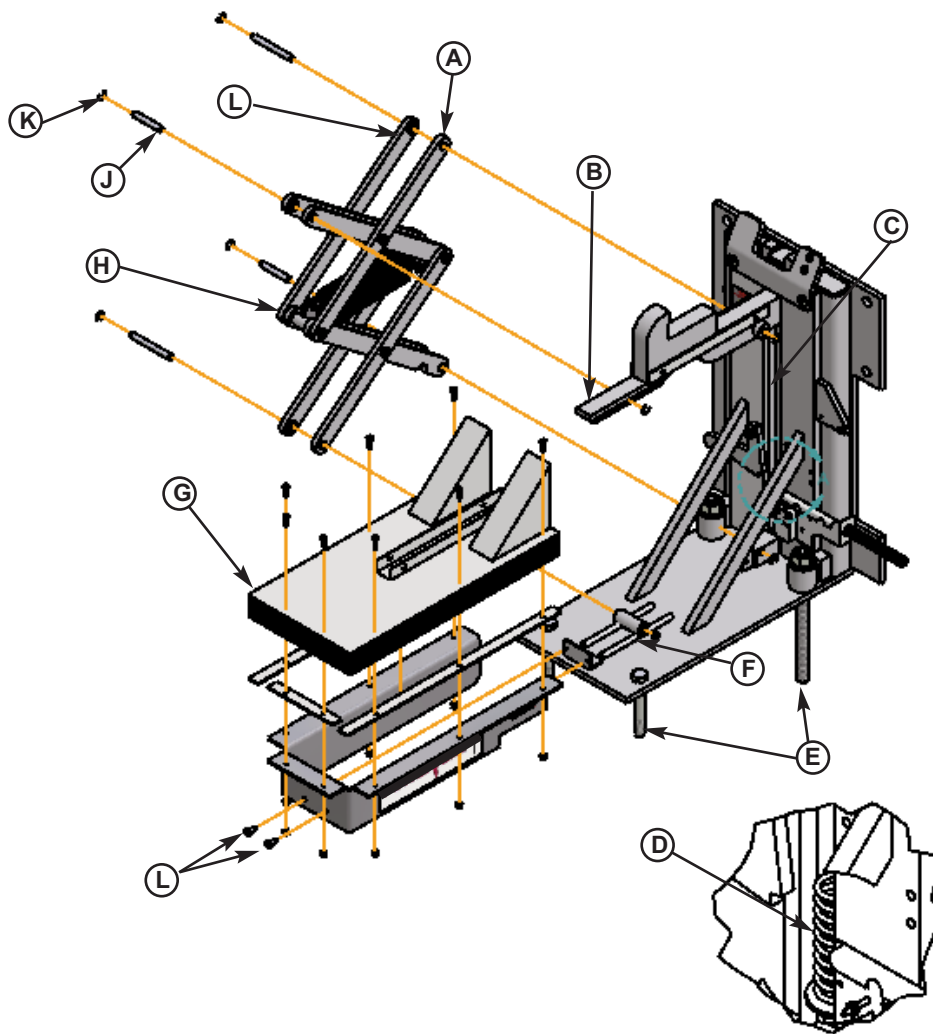

A—Scissors Assembly
B—Hook Weldment
C—Rear Vertical Track

D—Rear Track Assist Spring
E—Platform Hinge Area
F—Bottom Slide Track

G—Bellows
H—Main Springs
J—Pin

K—E-Clip
L—Bearing

WARNING

Before performing any maintenance under the dock leveler or truck restraint lock the electrical power source in OFF position using an approved locking device.

Failure to follow these instructions may result in serious personal injury or death.

IMPORTANT

Use of fluids that do not have equivalent specifications to those in the following list will result in abnormal operation of the truck restraint and voiding of warranty.

To ensure normal operation of the dock leveler, use only aircraft hydraulic fluid designed to meet or exceed military specification MIL-L-5606. It is recommended that the following hydraulic fluids be used:

- ULTRA-VIS-HVI-15
- Flomite 530 ZF
- Aero Shell Fluid 4 or Fluid 41
- Mobile Aero HFA Mil-HS606A or Aero HF
- Texaco Aircraft Hydraulic Oil 15 or 5606
- Exxon Univis J13

These fluid brands can be mixed together. Mixing with fluids that do not meet or exceed MIL-L-5606 may damage the equipment and WILL void warranty. Use of hydraulic fluids with equivalent specifications to those listed here are acceptable.

Daily Maintenance

- Daily patrol truck restraint area and clear any debris to prevent operation issues.
- Check inside and outside lights for proper operation

Weekly Maintenance

- Operate the truck restraint through the complete operating cycle to maintain lubrication of parts of both mechanical and hydraulic restraints.
- Inspect the rear vertical track area (C). The track area must be kept free of dirt and debris. Build-up of foreign material in the track areas will cause abnormal operation.

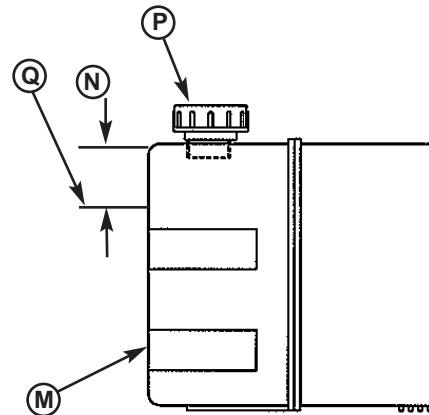

M—Reservoir
N—1 in. (25.5 mm) (From Top of Reservoir)
P—Breather Cap
Q—Fluid Level

IMPORTANT

Failure to clean and properly lubricate the truck restraint will cause abnormal operation.

Quarterly Maintenance

Clear all dirt and debris from the track areas to insure proper scissor operation and hook weldment travel.

NOTE: To thoroughly inspect and clean the scissors and track areas raise the restraint, remove two bolts (L), pull shroud & bellows forward to expose scissors and frame tracks,

Make sure Rear Track Assist Spring (D) is properly seated at the bottom of the rear track.

NOTE: Rear Track Assist Spring is different part number for mechanical and hydraulic PowerStop truck restraint

- Lubricate the following areas with light weight machine oil:

(A)—Scissor pins and bearings (J&L-all)

IMPORTANT

A low fluid level or the use of hydraulic fluids not equivalent to the fluid types recommended, will cause abnormal operation of the leveler and WILL void the warranty.

- Check reservoir fluid level (Q):
 1. Put the truck restraint in the stored position.
 2. Turn OFF all electrical power to the truck restraint.
 3. Wipe off plastic tank as needed (M).
 4. Measure fluid level. The fluid level should be approximately 1 in. (25.5 mm) (N) from top of reservoir (M) with truck restraint stored.
 5. Add hydraulic fluid if necessary. Use only recommended fluid. See previous page.
 6. Install cover.
 7. Turn ON electrical power.

PARTS

STOP-TITE® M (Mechanical) Parts Breakdown

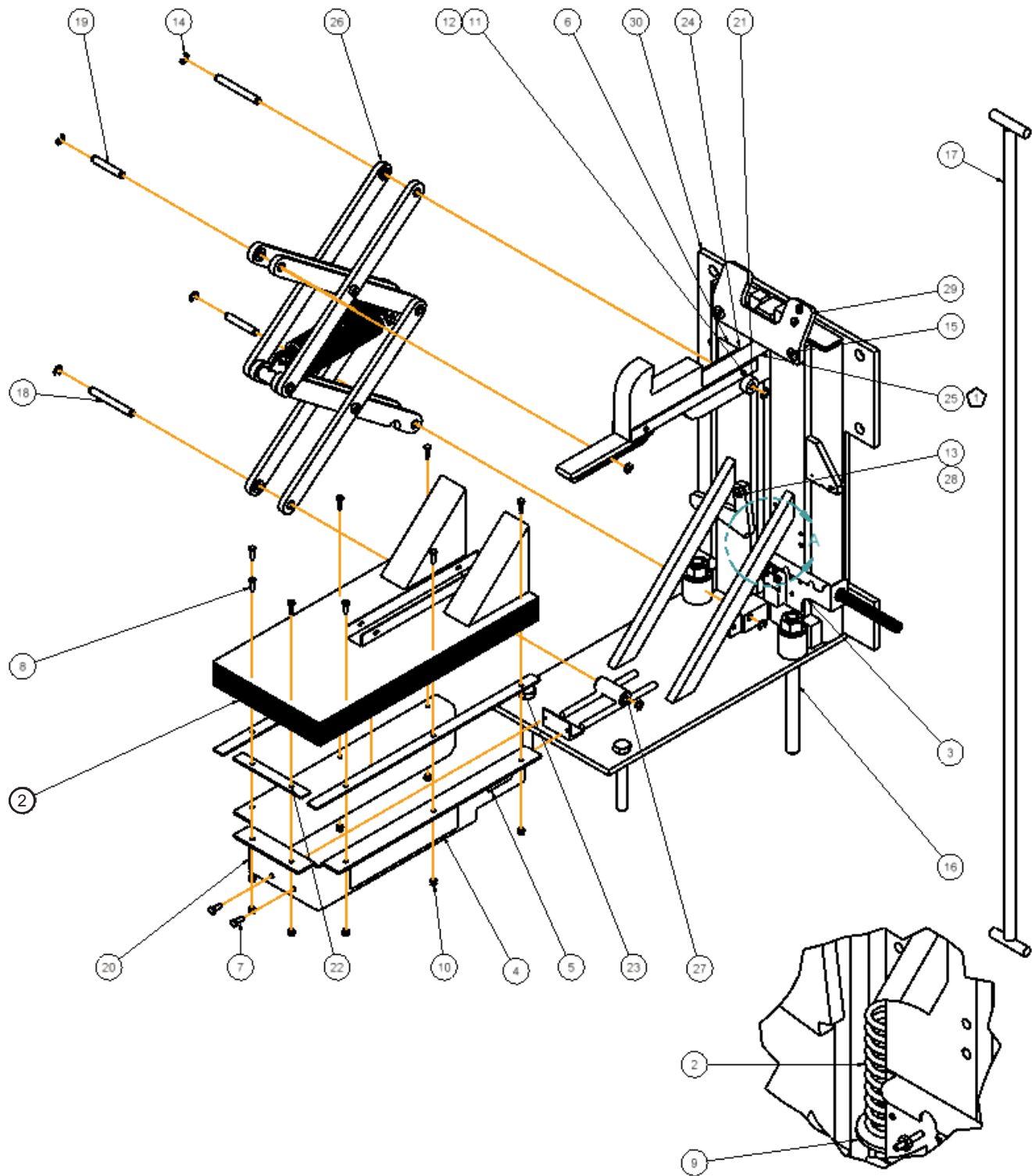

DETAIL A

STOP-TITE® M (Mechanical) Parts Breakdown

Item	Quantity	Part Number	Description
1	1	0191-0025	Bellows W/ 1 X 13=1/2 Velcro Strips
2	1	0941-0015	Spring, 1-7/8 DIA X 6.00
3	1	0615-0037	Stored Limit Switch with Bracket, NC
4	1	1751-0649	Decal-Systems, Inc./STOP-TITE®, 3-3/4 X 14-1./2
5	1	1751-0010	Decal-Serial Number
6	1	1751-0135	Decal-Warning
7	2	2101-0009	HHCS-Grade 2-Zinc Plated, 5-16-18 UNC X 3/4
8	8	2101-0084	HHCS-Grade 5-Zinc Plated , 1/4-20 UNC X 3/4
9	1	2101-0085	Washer-Flat-Zinc Plated, 1-1/8 DIA
10	8	2101-0143	Nylon Lock Nut, 1/4-20 UNC
11	2	2101-0150	RHMS-Slotted, 10-24 UNC X 2-1/4
12	2	2101-0151	Nylon Lock Nut, #10-24 UNC
13	1	2101-0165	Shoulder Bolt, 1/2 DIA X 5/8
14	8	2101-0189	E-Clip, 1/2
15	2	2101-0212	Flat Head Cap Screw, 1/2-13 UNC X 1
17	1	5455-0005	Level Weldment-Release
18	2	9202-0042	Pin-Pivot-Long, 1/2 DIA
19	2	9202-0043	Pin-Pivot-Short, 1/2 DIA
20	1	9411-0045	Shroud-Bellows Mounting-STOP-TITE®
21	2	9412-0161	Tube, 1-1/4 OD X 9-16 ID X 5/8
22	1	9412-0201	Bar-Bellows Mounting-Front
23	2	9412-0202	Bar-Bellows Mounting-Side
24	2	9412-0215	Bar-Bellows Mounting
25A	1	9413-0049	Restraint Weldment-STOP-TITE®-Standard Profile-2 Stage
25B	1	9413-0055	Restraint Weldment-STOP-TITE®-Low Profile-2 Stage
26	1	9413-0062	Scissor Lift Sub-Assembly-STOP-TITE®
27	1	9413-0068	Spacer Assembly-STOP-TITE® Mechanical
28	1	9413-0070	Release Lever Assembly-STOP-TITE® Mechanical
29	1	9413-0100	Deflector, Lip-27"-STOP-TITE®
30	1	9414-0062	Final Base Weldment-27"-STOP-TITE®
16	1	2103-0006	Driveway Mount - Optional

PARTS

STOP-TITE® A (Hydraulic) Parts Breakdown

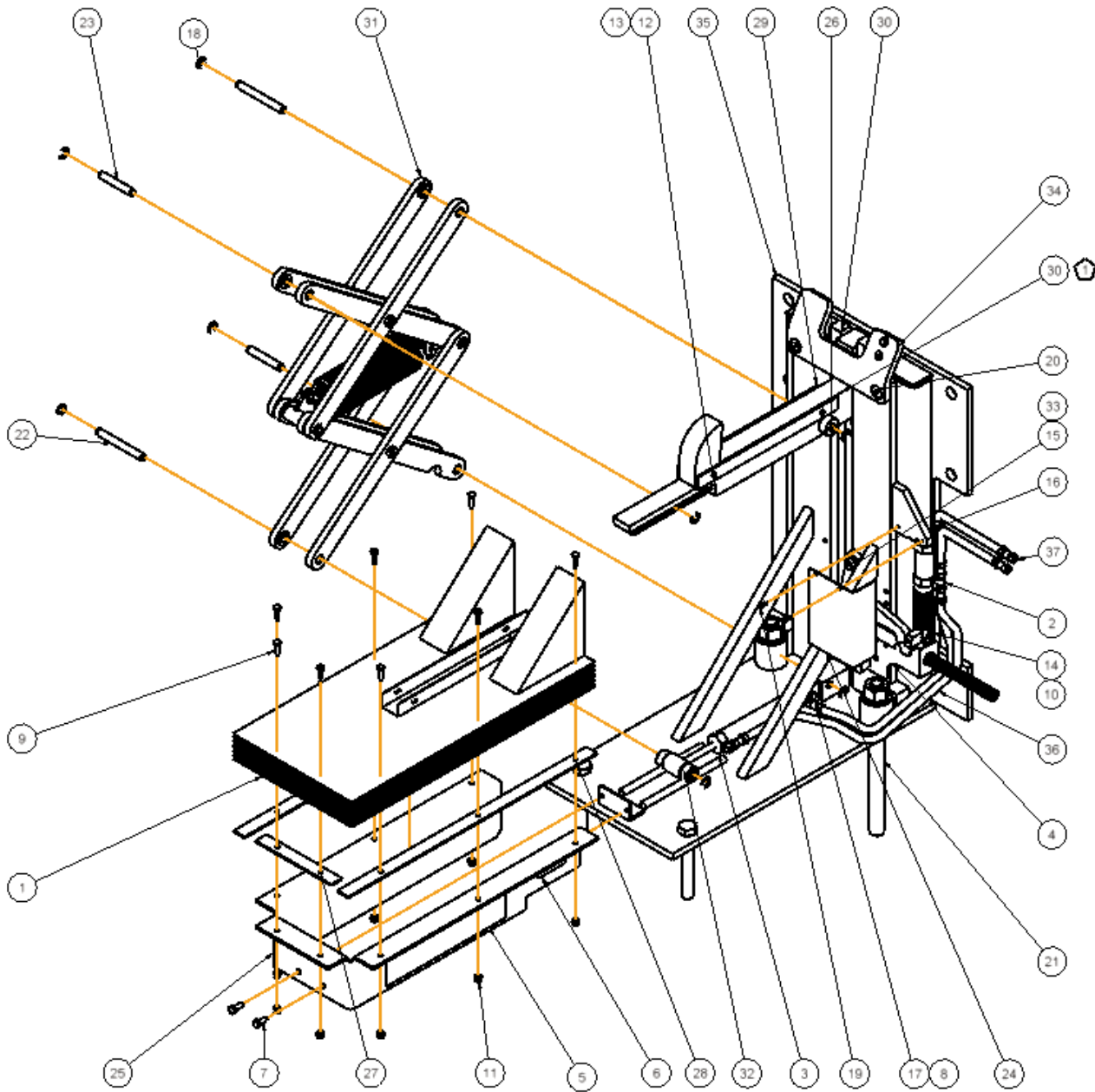

STOP-TITE® A (Hydraulic) Parts Breakdown

Item	Quantity	Part Number	Description
1	1	0191-0025	Bellows W/ 1 X 13=1/2 Velcro Strips
2	1	0524-0063	HYD Cylinder ASM, 1" Stroke
3	1	0524-0064	HYD Cylinder ASM, 5-3/4" Stroke
4	1	0615-0037	Stored Limit Switch with Bracket, NC
5	1	1751-0649	Decal-Systems, Inc./STOP-TITE®, 3-3/4 X 14-1/2
6	1	1751-0010	Decal-Serial Number
7	2	2101-0009	HHCS-Grade 2-Zinc Plated, 5/16-18 UNC X 3/4
8	1	2101-0039	Nylon Lock Nut,5/16-18 UNC
9	8	2101-0084	HHCS-Grade 5-Zinc Plated, 1/4-20 UNC X 7/8
10	1	2101-0098	HHCS-Grade 5-Zinc Plated, 5/16-18 UNC X 1-3/4
11	8	2101-0143	Nylon Lock Nut, 1/4-20 UNC
12	2	2101-0150	RHMS-Slotted, 10-24 UNC X 2-1/4
13	2	2101-0151	Nylon Lock Nut, #10-24 UNC
14	1	2101-0163	Washer-Flat-Zinc Plated, 1/2 DIA X 5/8
15	1	2101-0165	Shoulder Bolt, 1/2 DIA X 5/8
16	1	2101-0187	HHCS-Grade 5, 5/16-18 UNC X 1
17	1	2101-0188	HHCS-Grade 5, 5/16-18 UNC X 1-1/4
18	8	2101-0189	E-Clip, 1/2"
19	2	2101-0202	RHMS-Phillips, 10-32 UNF X 1-3/4
20	2	2101-0212	Flat Head Cap Screw, 1/2-13 UNC X 1
22	2	9202-0042	Pin Pivot Long, 1/2 DIA
23	2	9202-0043	Pin Pivot Short, 1/2 DIA
24	1	9411-0044	Shroud-Cylinder, 1/16 X 2-1/16 X 4-1/2 X 6
25	1	9411-0045	Shroud-Bellows Mounting-STOP-TITE™
26	2	9412-0161	Tube, 1-1/4 OD X 9/16 ID X 5/8
27	1	9412-0201	Bar-Bellows Mounting-Front, Painted-1/8 X 1 X 7
28	2	9412-0202	Bar-Bellows Mounting-Side, Painted-1/8 X 1 X 23
29	1	9412-0215	Bar Bellows mounting, Painted-1/8 X 1 X 13
30	1	9413-0055	Restraint Weldment-STOP-TITE®-Low Profile
31	1	9413-0062	Scissor Lift Sub-Assembly-STOP-TITE®
32	2	9413-0069	Spacer Assembly-STOP-TITE®-A
33	1	9413-0071	Release Lever Assembly
34	1	9413-0100	Hook Stop-27" STOP-TITE®
35	1	9414-0062	Final Base Weldment-27"-STOP-TITE®
36	1	9904-0097	Hydraulic Hose ASM-1/4" 100R1 X 24", #4 JICF Swivel Both Ends
37	1	9904-0119	Hydraulic Hose, 1/4" 100R1 X 96", #4 JICF Swivel Both Ends
21	1	2103-0003	Wall Mount Kit - Option
*	1	0522-0002	Spring, Helper, Rear Frame (Not Shown)

PARTS

Power Pack Assembly

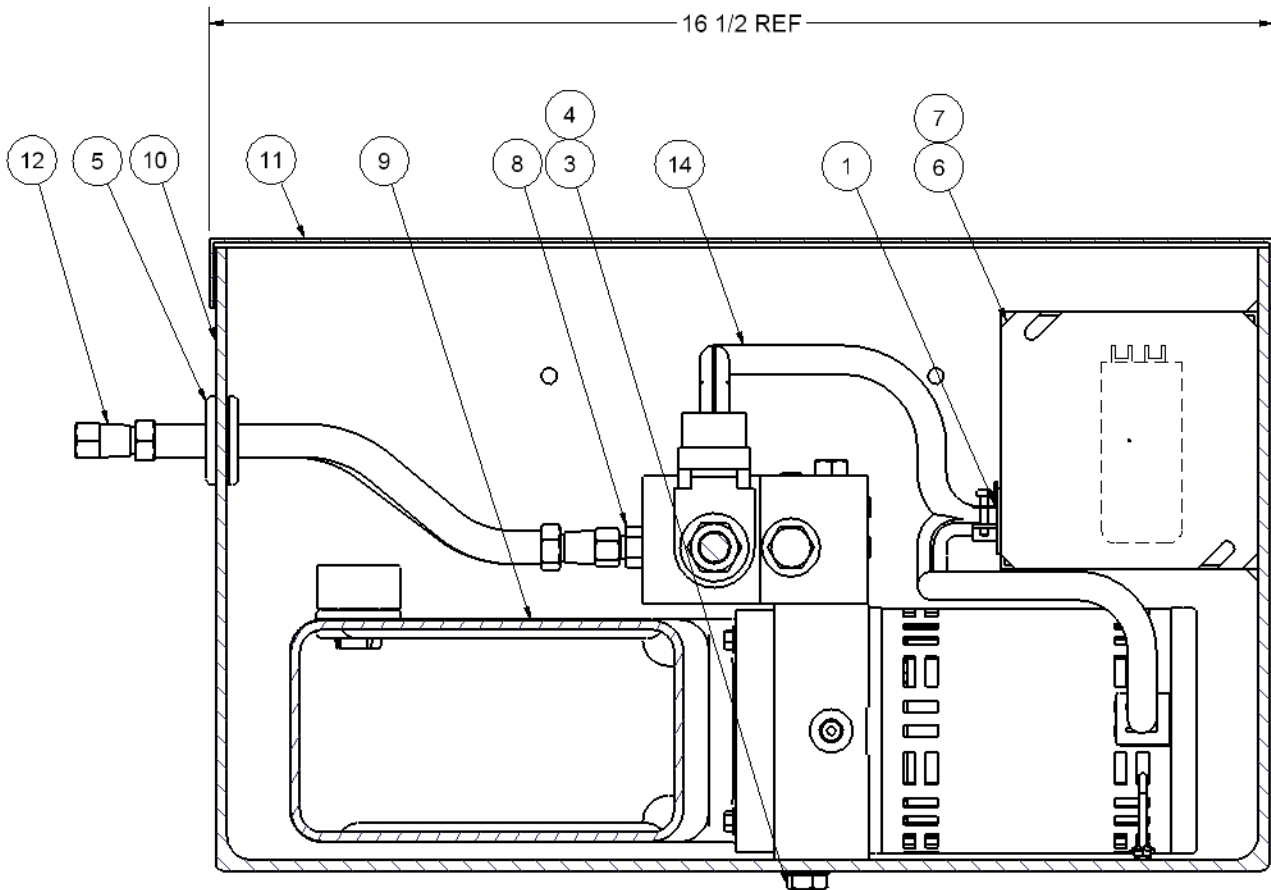
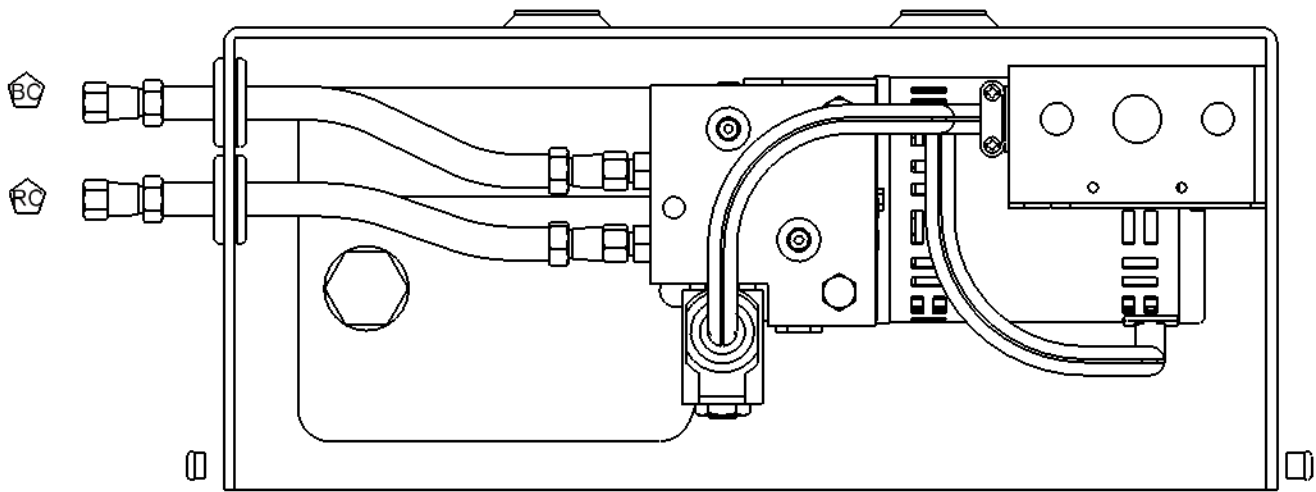

AMP Draw 4.8-5.2

Power Pack Assembly

Item	Quantity	Part Number	Description
1	1	1431-0011	Connector-2 Screw, 3/8
2	3	1431-0086	Insulated Terminals, 16-14 AWG
3	2	2101-0017	HHCS-Grad 2-Zinc Plated, 3/8-16 UNC X 1
4	2	2101-0140	Lock Washer, 3/8
5	2	2401-0001	Grommet, 1-3/8 OD X 3/4 ID
6	1	2751-0016	J-Box Cover, 4 X 4
7	1	3051-0058	Capacitor-Motor Start, 66-77mf-330V
8	1	9301-0164	Fitting Connector Straight Thread, #4 ORB #4 JIC
9	1	9391-0009	Powerpack-STOP-TITE™, 1PH-115V-1/4HP-1GPM
10	1	9391-0038	Powerpack Mounting Weldment
11	1	9391-0039	Cover-STOP-TITE®
*12	2	9904-0119	Hydraulic Hose ASM-1/4" 100R17 X 96, #4 JICF Swivel Both Ends
13	1	R513-0050	Wire, 16 GA Red X 5.00
14	2	R598-0090	Split Flex Conduit, 1-4 X 9.00
*			Hose Lengths Vary by Job

BC = Blind End of Cylinder

RC = Rod End of Cylinder

PARTS

Outside Signs

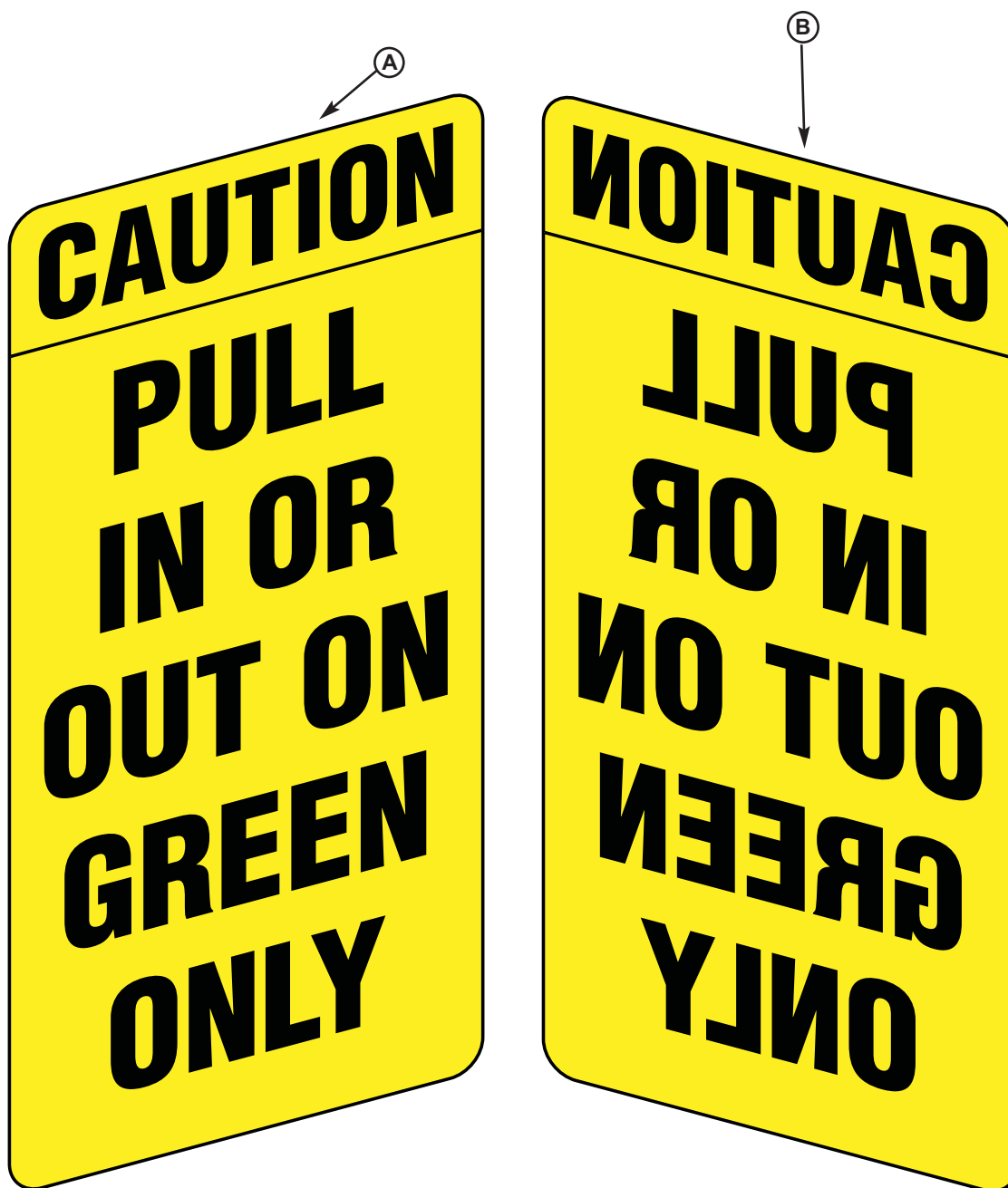

Item	Quantity	Part Number	Description
A	1	1751-0133	SIGN,PULL IN/OUT ON GREEN ONLY RIGHT READING,16-7/8x8x3/32
B	1	1751-0134	SIGN,PULL IN/OUT ON GREEN ONLY MIRROR IMAGE,16-7/8x8x3/32

OSLA (Outside Light Assembly)

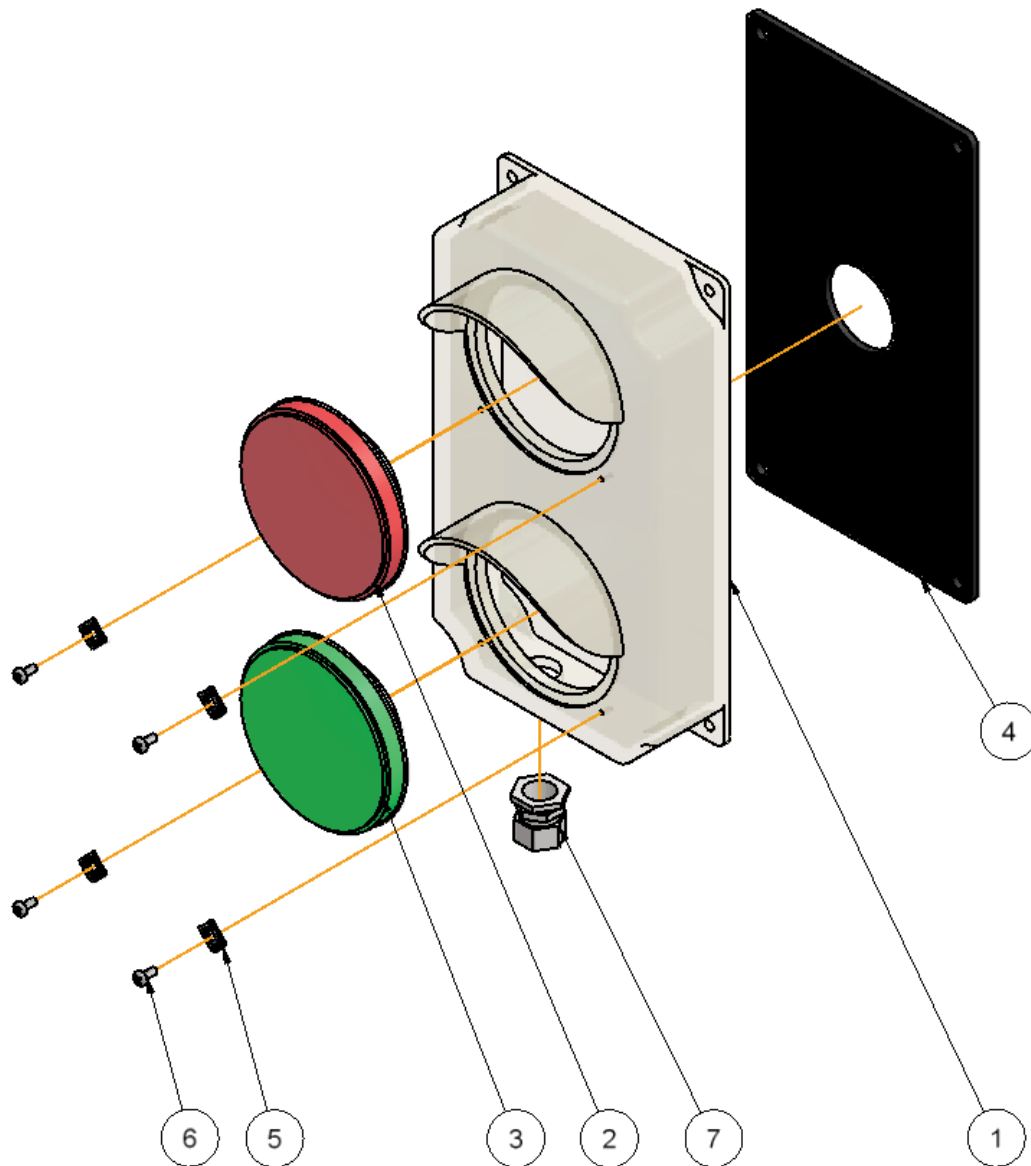

Item	Quantity	Part Number	Description
1-7	1	3055-0008	Complete Light Housing, Yellow Plastic, LED Lights
1-7	1	3055-0002	Complete Light Housing, Yellow Plastic, Incandescent Lights
1	1	3051-0002	Light Housing Only, Yellow Plastic
2	1	3051-0064	Lens Red, for use with incandescent bulbs
3	1	3051-0065	Lens Green, for use with incandescent bulbs
*	2	3051-0085	Lamp, 25W,120V,Incandescent, BAY (Rated 1000 Hours)
*	2	3051-0066	Socket Harness for Incandescent Lamp
2	1	3051-0102	Lens/Housing/Circuit Assembly Red-LED
3	1	3051-0103	Lens/Housing/Circuit Assembly Green-LED
4	1	3051-0068	Mounting Gasket
5	4	3051-0105	Clips, Lens Holding
6	4	3051-0104	Screw, Lens Holding Clip
7	1	x	Conduit Fastener, 3/4" x 3/8"

NOTES

This Page Intentionally Left Blank

Customer Information

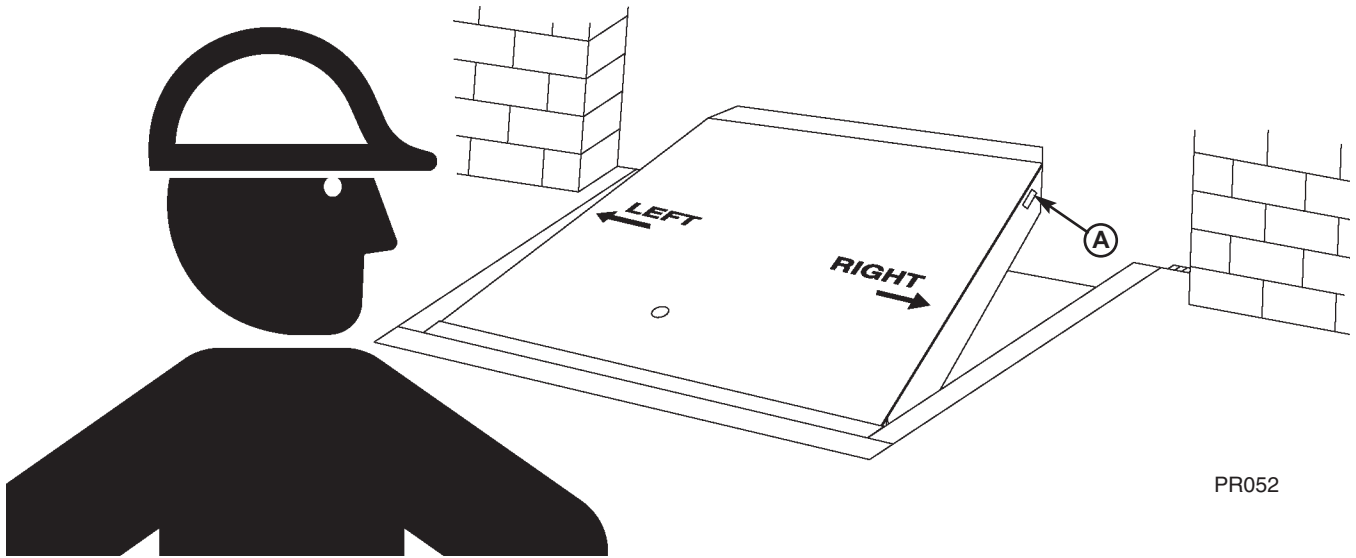

PR052

NOTE: Refer to illustration for left/right orientation of Dock Leveler and Truck Restraint.

The model/serial number decal (A) is located on the right platform joist near the front (lip) of dock leveler. The Truck Restraint serial number is located on the left side of the bellows shroud.

When you receive your STOP-TITE® Truck Restraint, write down the Truck Restraint and Dock Leveler serial number (if applicable) in the form provided. This will help ensure safe keeping of the numbers in the event the model/serial number decal (A) becomes lost or damaged.

Also, write down McGuire's job number (found inside the control box door on a white sticker), the company that installed the dock leveler, and the original owner's name. This will all help to identify the specific dock leveler if more information is required.

When ordering, use part numbers and description to help identify the item ordered. Do not use "item" numbers. These are only for locating the position of the parts. Always give truck restraint MODEL NUMBER and/or SERIAL NUMBER.

For service, call or contact:

McGuire
 P.O. Box 309
 Germantown, WI 53022
 Phone: (800) 624-8473
 Fax: (262) 255-5917

Truck Restraint Information

Model _____

Serial No. _____

McGuire's, Job No. _____

Dock Leveler Information

Model _____

Serial No. _____

McGuire's Job No. _____

Original Owner Information

Name _____

Address _____

Installer Information

Name _____

Address _____

Date of Installation _____

McGuire WARRANTY

STOP-TITE® SERIES TRUCK RESTRAINT

McGuire, guarantees the materials, components, and workmanship in your McGuire truck restraint to be of the highest quality and to be free of defects in material and workmanship for a period of One (1) Year from date of shipment. Specifically this includes the frame and all mechanical components.

McGuire, further guarantees the hydraulic components (where equipped) on all McGuire truck restraints for a period of One (1) Year from date of shipment.

Specifically this guarantee applies to:

- Fluid valves and valve body control assembly
- All hydraulic cylinders
- Hydraulic pressure lines
- Hydraulic pump and motor.

The electrical components carry a One (1) year warranty.

In the event of any defect covered by this guarantee, McGuire will remedy said defect by repairing or replacing all defective parts, bearing all of the costs for parts, labor, and transportation.

All guarantee claims will be settled on a timely basis when defects are found to be from other than improper installation, operating contrary to instructions or beyond rated load capacities, abuse, careless or negligent use, or failure to maintain the unit as recommended by the owner's manual.

There are no guarantees, either expressed or implied, including any implied guarantees of merchantability or fitness for a particular purpose which shall extend beyond the guarantee periods indicated above. This guarantee is valid only if the unit(s) is unaltered from original condition as delivered from the factory and a survey is completed by a McGuire representative.