

**RC200
INFLATABLE RAIL SHELTER**

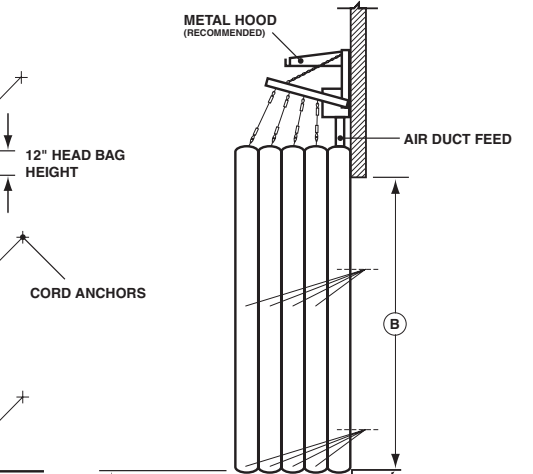
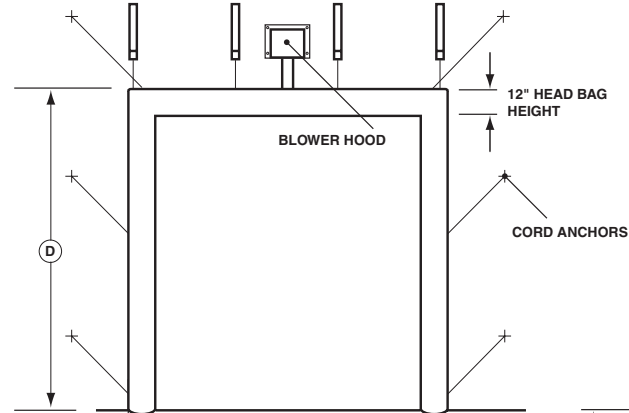
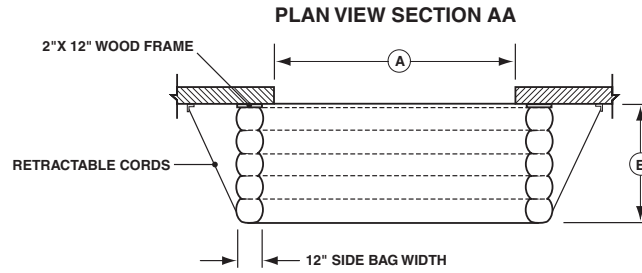
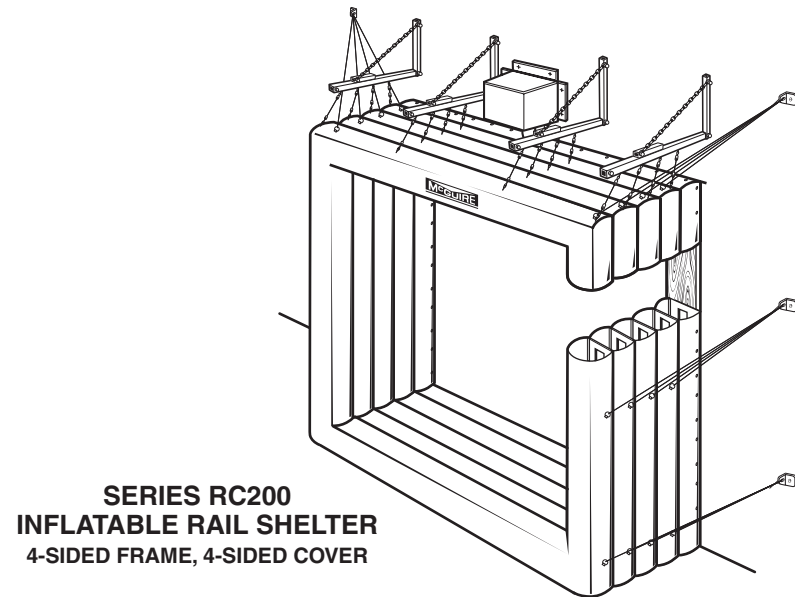
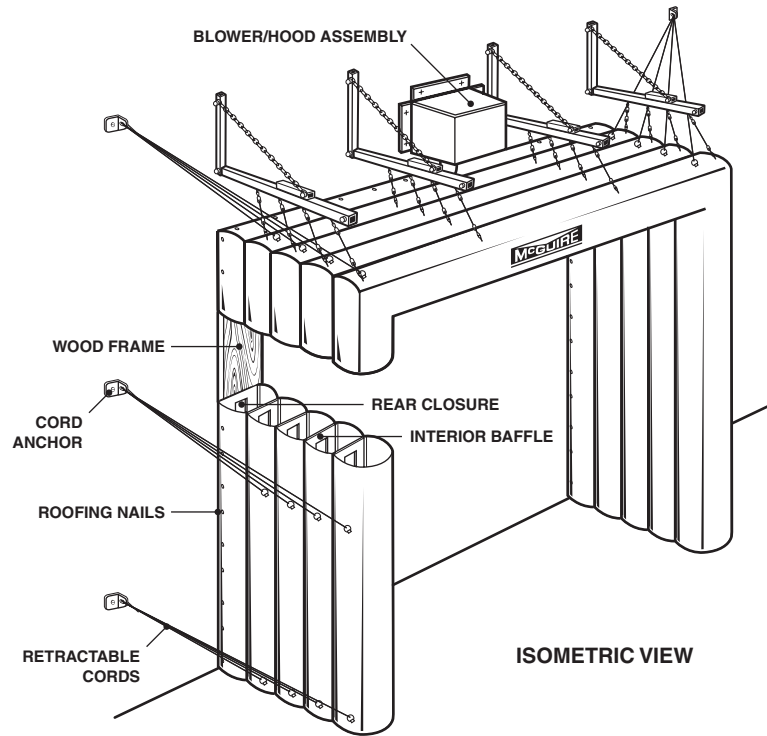

- _____ "A" DOOR WIDTH
- _____ "B" DOOR HEIGHT
- _____ "C" UNIT WIDTH
- _____ "D" UNIT HEIGHT
- _____ "E" UNIT PROJ.
- _____ "F" DOCK HEIGHT (FROM TOP OF RAIL)
- _____ "G" DIMENSION TO NEAREST RAIL
- PERMANENT RAIL RAMP
- CANTILEVER DOCK _____ HIGH BY _____ PROJ.
- OUTSIDE SLIDING DOOR

- FABRIC TYPE**
- AIRE LITE (BLACK)
- OPTIONS**
- FORMED STEEL FRAME (MIN. 14 GA.)
 PAINTED GALVANIZED
- DROP CURTAIN _____" LONG

- PULL ROPE ASSEMBLY FOR ABOVE
- OVERHEAD TRACK (VS. RETRACTABLE CORDS)
- ALTERNATE BLOWER LOCATION
 RIGHT OF UNIT
 LEFT OF UNIT

FB- _____ QTY. _____ SHEET _____ OF _____



205 BROADVIEW STREET • P.O. BOX 151
 UPPER SANDUSKY, OH 43351
 PHONE 1.800.262.1188
 FAX 419.294.4980
 WWW.WBMCGUIRE.COM

JOB: _____

LOCATION: _____

CONTRACTOR: _____ ARCHITECT: _____

APPROVED BY SIGNATURE: _____