



A Division of Systems, Inc.

MEDLF SERIES

**Mechanical EOD
Dock Leveler**

Owner's/User's Manual





McGUIRE • Division of Systems, Inc. • W194 N11481 McCormick Drive • Germantown, WI 53022
800.624.8473 • fax: 262.255.9399 • www.wbmcguire.com • techservices@docksystemsinc.com

Table of Contents

	Page
Safety	
Recognize Safety Information	1
General Operational Safety Precautions	1
Operational Safety Precautions	2
Maintenance Safety Precautions	4
Safety Decals	5
Introduction	
General Information	6
Dock Leveler Stock Specifications	6
Installation	
Installation Details	7
Flush Mount-Weld On	8
Ramp Mount - Weld/Bolt On	10
Flush Mount - Bolt On	12
Ramp Mount - Weld On w/Formed Angle	14
Formed Angle	16
Ramp and Face Plate	18
Installation Checklist	20
Operation	
Operating Instructions	21
Maintenance	
Periodic Maintenance	22
Troubleshooting	
Troubleshooting	23
Parts	
MEDLF Series	24
Torsion Spring Components	26
Bumper Components	28
Sliding Bumper Components	29
Miscellaneous	
Customer Information	31
Warranty	Back Cover

Recognize Safety Information

Safety-Alert Symbol

The <u>Safety-Alert Symbol</u> identifies important safety messages on equipment, safety signs, in manuals, or elsewhere. When you see this symbol, be alert to the possibility of personal injury or death. Follow the instructions in the safety message.

 DANGER
The use of the word <u>DANGER</u> signifies the presence of an extreme hazard or unsafe practice which will most likely result in severe injury or death.

 WARNING
The use of the word <u>WARNING</u> signifies the presence of a serious hazard or unsafe practice which may result in serious injury or death.

 CAUTION
The use of the word <u>CAUTION</u> signifies possible hazard or unsafe practice which could result in personal injury.

IMPORTANT
The use of the word <u>IMPORTANT</u> is to draw attention to a procedure that needs to be followed to prevent machine damage.

General Operational Safety Precautions

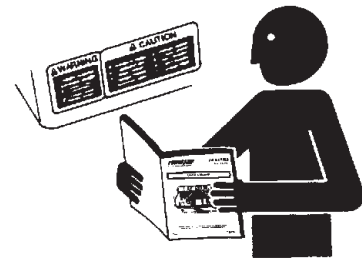

Read and understand the operating instructions and become thoroughly familiar with the equipment and its controls before operating the dock leveler.

Never operate a dock leveler while a safety device or guard is removed or disconnected.

Never remove DANGER, WARNING, or CAUTION signs or decals on the equipment unless replacing them.

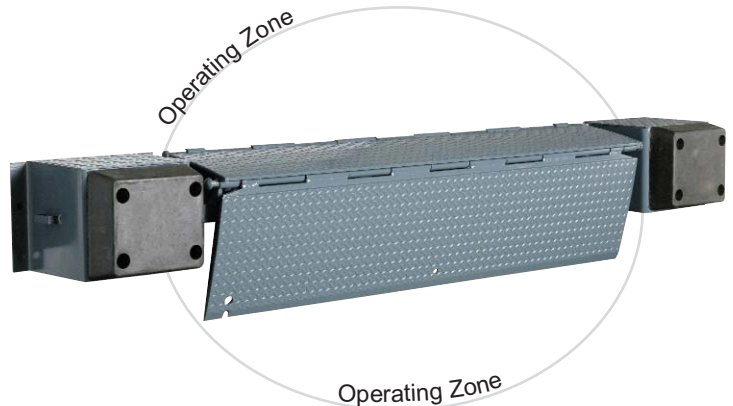

Do not start the equipment until all unauthorized personnel in the area have been warned and have moved outside the operating zone.

Remove any tools or foreign objects from the operating zone before starting.

Keep the operating zone free of obstacles that could cause a person to trip or fall.

SAFETY

Operational Safety Precautions



Learn the safe way to operate this equipment. Read and understand the manufacturer's instructions. If you have any questions, ask your supervisor.



DANGER



Stay clear of dock leveling device when freight carrier is entering or leaving area.



Do not move or use the dock leveling device if anyone is under or in front of it.

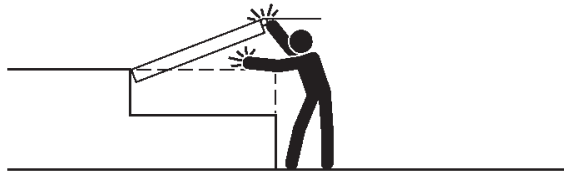

Keep hands and feet clear of pinch points. Avoid putting any part of your body near moving parts.



WARNING



Chock/restrain all freight carriers. Never remove the wheel chocks until loading or unloading is finished and truck driver has been given permission to drive away.



Do not use a broken or damage dock leveling device. Make sure proper service and maintenance procedures have been performed before using.

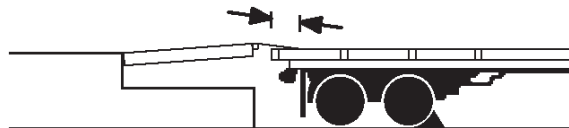

Make sure lip overlaps onto trailer at least 4 in. (102 mm).

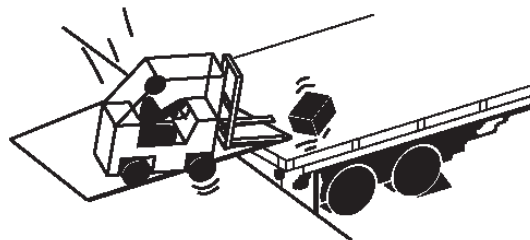

Keep a safe distance from both side edges.

Safety Decals

WARNING

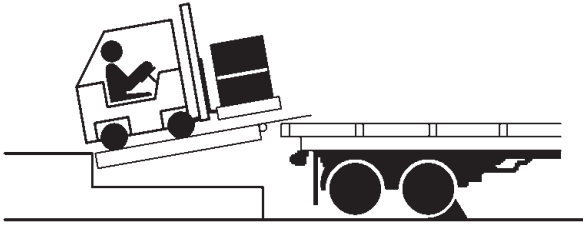

Do not use dock leveling device if freight carrier is too high or too low.



Do not overload the dock leveling device.

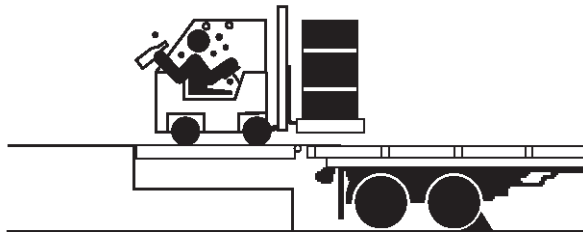

Do not operate any equipment while under the influence of alcohol or drugs.

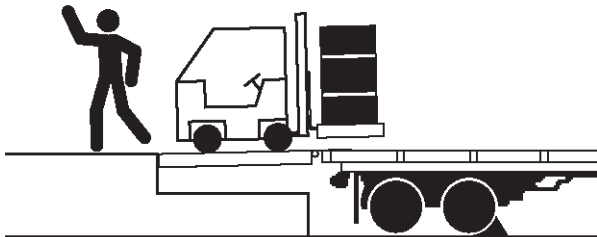

Do not leave equipment or material unattended on dock leveling device.

SAFETY

Maintenance Safety Precautions

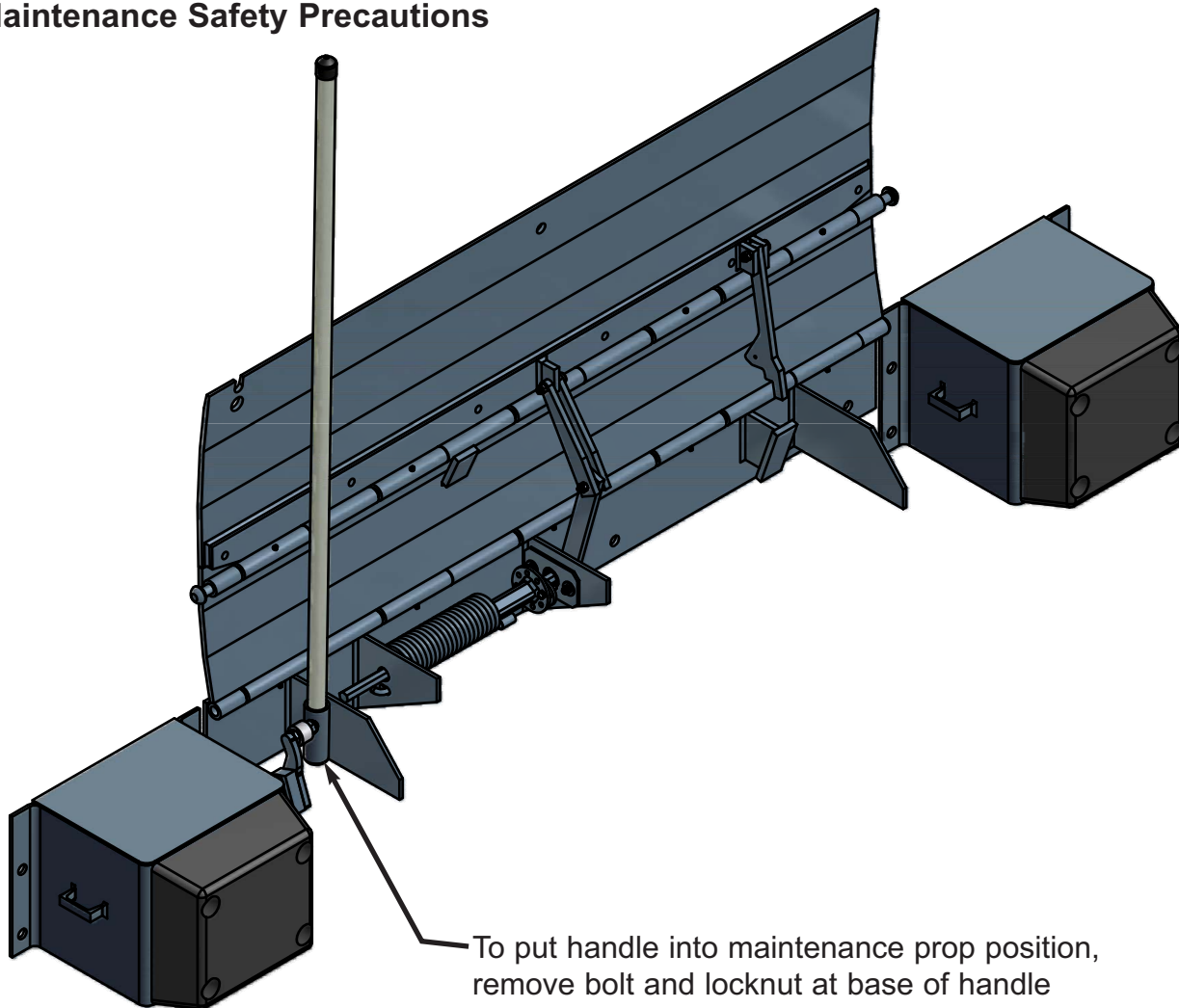

To put handle into maintenance prop position, remove bolt and locknut at base of handle assembly. Pull handle out of roller arm assembly and place into maintenance prop receiver.



WARNING

ALWAYS stand clear of dock leveler lip when working in front of the dock leveler. Failure to do this may result in serious personal injury or death.



WARNING

Post safety warnings and barricade the work area at dock level and ground level to prevent unauthorized use of the dock leveler before installation has been completed.

Failure to follow the installation instructions can result in damage to dock leveler, the facilities, and/or serious personal injury or death.

Safety Decals

②

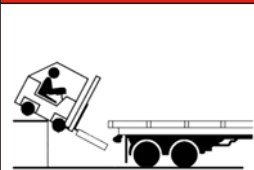

! DANGER

Unsupported dock leveler ramps can lower unexpectedly.

Before allowing vehicle to leave the dock always:

- Ensure that no equipment, material or people are on the dock leveler.
- Return the dock leveler to its stored position at dock level.

SAFETY INFORMATION

<p>Operation</p> <ol style="list-style-type: none"> Read and follow all instructions and warnings in the owner's/user's manual. Use of dock leveler restricted to trained operators Always chock trailer wheels or engage truck restraint before operating dock leveler or beginning to load or unload. Never use hands or equipment to move the ramp or lip Before activating dock leveler: <ul style="list-style-type: none"> Ensure trailer is backed in against bumpers. Remove any end loads if required. Check trailer alignment to avoid lip interference. If lip does not lower to trailer bed, reposition vehicle. Ensure that truck bed supports extended lip or the leveler frame 	<p>Supports the ramp before driving on ramp.</p> <ol style="list-style-type: none"> Stay clear of hinges and front and sides of moving dock leveler. Never use damaged or malfunctioning dock leveler. Report problems immediately to supervisor. <p style="text-align: center;">Maintenance/Service</p> <ol style="list-style-type: none"> Read and follow all instructions, warnings and maintenance schedules in the owner's/user's manual. Maintenance/Service of dock leveler restricted to trained personnel. Place barriers on the driveway and on dock floor to indicate service work is being performed. DO NOT ENTER PIT unless dock leveler is securely supported by maintenance prop. If electrically powered turn off and use OSHA lockout/tagout procedures.
---	---

Call 262.255.1510 for replacement placards, warning labels, or owner's/user's manuals.

Failure to follow posted instructions will result in death or serious injury.

②

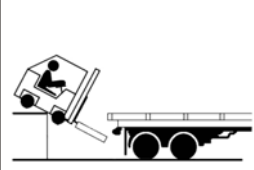

! DANGER

Unsupported dock leveler ramps can lower unexpectedly.

Before allowing vehicle to leave the dock always:

- Ensure that no equipment, material or people are on the dock leveler.
- Return the dock leveler to its stored position at dock level.

SAFETY INFORMATION

<p>Operation</p> <ol style="list-style-type: none"> Read and follow all instructions and warnings in the owner's/user's manual. Use of dock leveler restricted to trained operators Always chock trailer wheels or engage truck restraint before operating dock leveler or beginning to load or unload. Never use hands or equipment to move the ramp or lip Before activating dock leveler: <ul style="list-style-type: none"> Ensure trailer is backed in against bumpers. Remove any end loads if required. Check trailer alignment to avoid lip interference. If lip does not lower to trailer bed, reposition vehicle. Ensure that truck bed supports extended lip or the leveler frame 	<p>Supports the ramp before driving on ramp.</p> <ol style="list-style-type: none"> Stay clear of hinges and front and sides of moving dock leveler. Never use damaged or malfunctioning dock leveler. Report problems immediately to supervisor. <p style="text-align: center;">Maintenance/Service</p> <ol style="list-style-type: none"> Read and follow all instructions, warnings and maintenance schedules in the owner's/user's manual. Maintenance/Service of dock leveler restricted to trained personnel. Place barriers on the driveway and on dock floor to indicate service work is being performed. DO NOT ENTER PIT unless dock leveler is securely supported by maintenance prop. If electrically powered turn off and use OSHA lockout/tagout procedures.
---	---

Call 262.255.1510 for replacement placards, warning labels, or owner's/user's manuals.

Failure to follow posted instructions will result in death or serious injury.

Decal 2 will have two positions, one on the outside of the left bumper and one on the outside of the right bumper. Number 3 represents the placement of the serial tag.

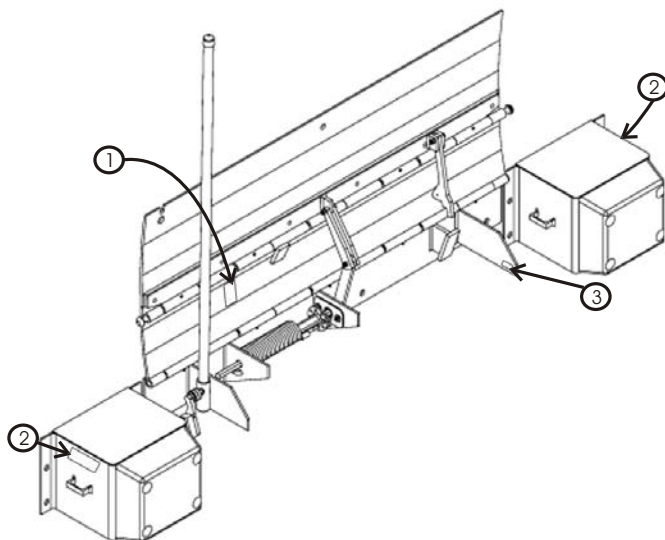

①

! DANGER



**Ramp swings toward you.
Stand Clear.
Use maintenance strut while servicing.
Failure to do so will result in death or serious injury.**

INTRODUCTION

General Information

MEDLF Series Edge-of-Dock levelers are available in the following sizes, weight capacities, and options:



Congratulations on your choice of a McGuire Edge-of-Dock leveler. This manual covers the MEDLF series mechanical Edge-of-Dock levelers.

Designed by McGuire to be a marvel of simplicity and efficiency, your dock leveler, when properly installed, will provide many years of trouble-free performance with an absolute minimum of maintenance. To obtain maximum performance and longest possible use, a simple program of preventive maintenance is recommended.

Once again, thank you and congratulations on your purchase of a McGuire mechanical Edge-of-Dock leveler.

Dimensions and Capacities			
Model # -	Deck - Width	Total Unit Width	Comparative Industry Rating
MEDLF-66	66"	104"	20,000
MEDLF-72	72"	110"	25,000
MEDLF-78	78"	116"	30,000
MEDLF-84	84"	122"	35,000 (N/A for MEDLF-78 & 84)

INSTALLATION DETAILS

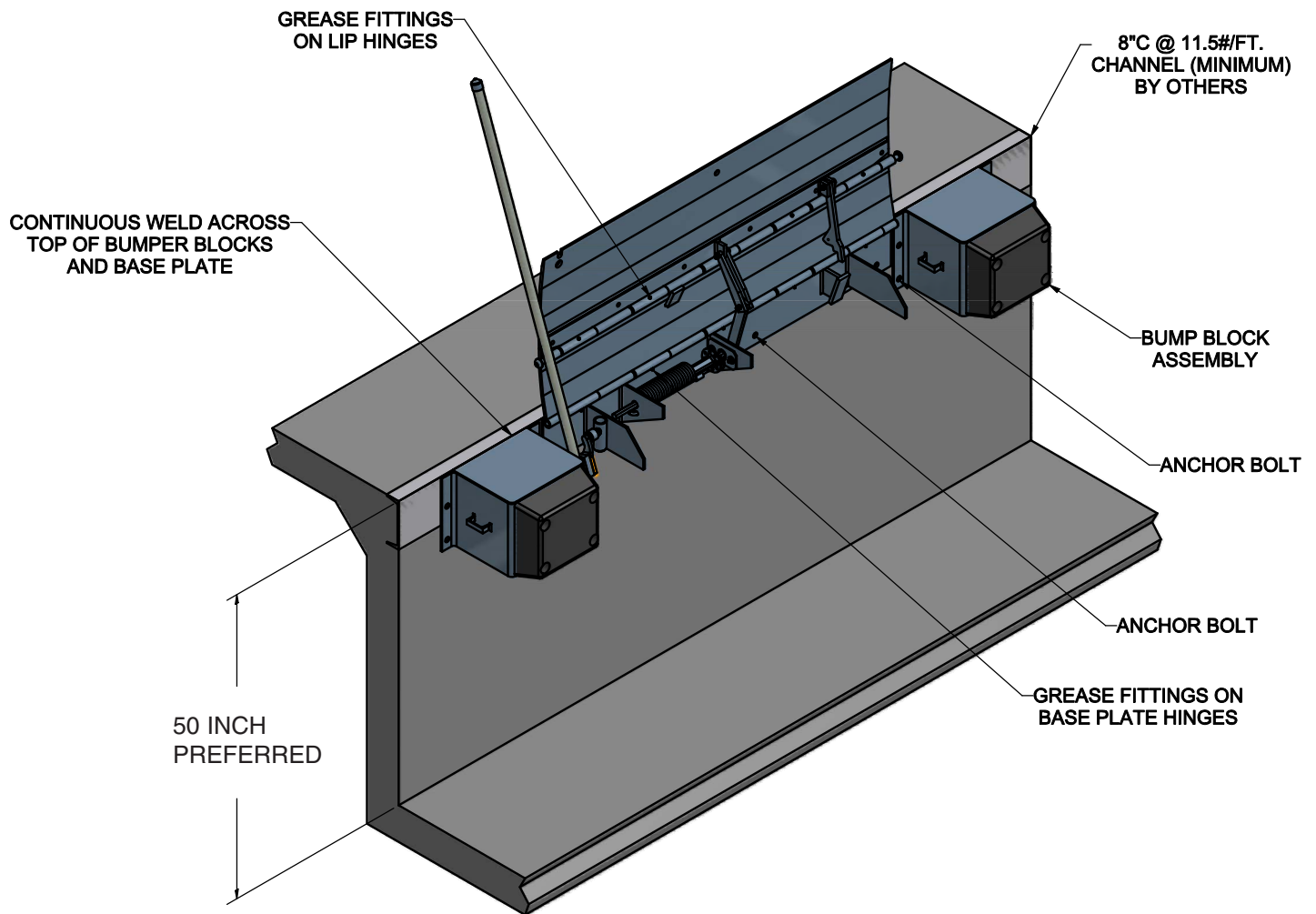

CAUTION

Only trained installation professionals with the proper equipment should install this product.

IMPORTANT

DO NOT remove the shipping bands around the dock leveler lip until instructed to do so.



WARNING

Post safety warnings and barricade the work area at dock level and ground level to prevent unauthorized use of the dock leveler before installation has been completed.

Failure to follow the installation instructions can result in damage to dock leveler, the facilities, and/or serious personal injury or death.

INSTALLATION

E.O.D. Installation Instructions Flush Mount - Weld On

A flush mount weld on application is used when an 8" wide (minimum) embed channel is securely anchored into the concrete at the dock edge, and the dock height is adequate.

Installation Steps:

1. Remove all existing bumper material and protruding objects from dock edge. Clean and sweep dock edge free of debris and flammable chemicals before installing unit.
2. At chosen location for Edge of Dock leveler, locate the center of space and mark a point half of the base plate width to the left and right.
3. Using a proper lifting device, raise and position leveler on dock face with the top of the base plate being flush with the top of the embedded channel. Position ends of base plate to match up with marks made previously.
4. Tack weld base plate to dock steel on left hand end of the leveler. Check right hand end of base plate, ensure that end is against dock steel and that the top of the base plate is still flush with the top of the embedded channel. Tack right hand end to dock steel.
5. Position bump blocks out approximately 5/8" from the edge of the inside flange of the bump block to the end of the base plate. This will allow for vertical welding of both the base plate and the bump block flange back to the dock steel. Top of the bump block cover plate should be flush with the top of the embed channel. Tack weld bump blocks to dock steel.
6. Check the positioning of the base plate and the bump blocks.
7. Complete welding of tacked parts as follows:
 - A. Apply a continuous weld across top of each bumper and base plate to dock steel. Skip welding is acceptable to prevent warpage, but complete weld across the top must be completed.
 - B. Weld vertically along each end of base plate and on both inboard and outboard flanges of bump blocks.
 - C. Fully plug weld all holes in base plate.
8. Installer must remove all welding slag, and repaint welded areas.
9. Installer must adjust springs on all mechanical edge of dock levelers to provide desired tension for smooth operation. Stand on ground in front of leveler, with the unit raised and secured in the maintenance position, loosen jam nut on the underside of the linkage pin. To start allow about 3/4" to 1" of threads between top of jam nut and linkage pin. Using an open faced wrench, hold locknut on inside of spring while tightening threaded bolt until washer on top side of spring closes up tight to jam nut. Test operation of unit. Further adjust spring tension if needed by advancing jam nut toward linkage pin and tightening threaded rod. After desired unit operation is achieved, tighten jam nut to outer washer on spring. Springs must be adjusted alternately to have equal spring tension.
10. Before install is complete, installer must make a final operational check of dock leveler to verify all phases of install are correct. Installer must complete, sign and return the Installation Checklist upon completion.

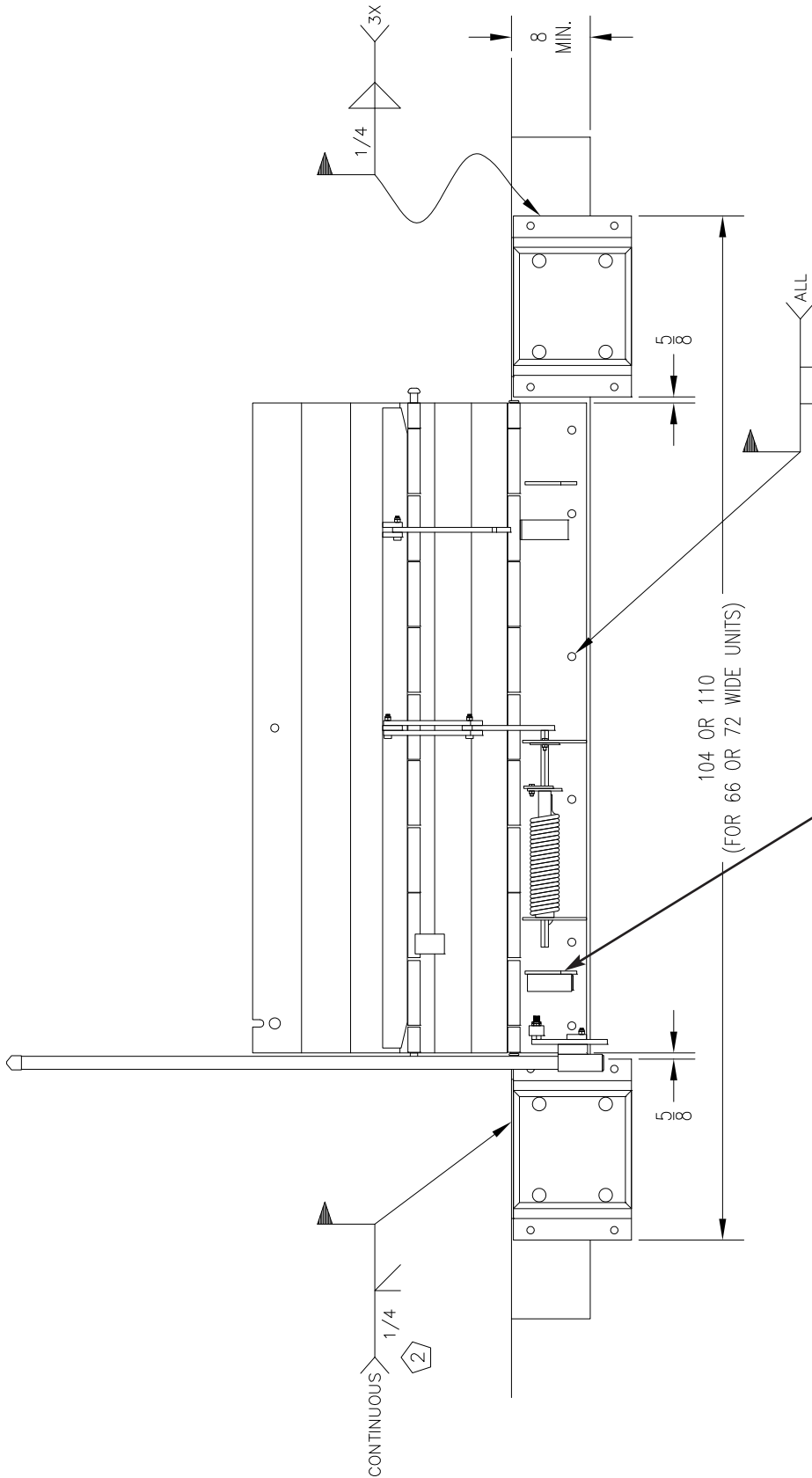

WARNING

Securely block or support ramp and lip when in vertical positions. Lack of proper bracing can result in ramp dropping during adjustment or installation causing personal injury or damage to unit.

NOTE	DESCRIPTION
1	Top of base plate and bumper cover plate to be flush with top of dock floor and embedded channel
2	Apply continuous bevel weld across both bumpers and length of base plate.

INSTALLATION

E.O.D. Installation Instructions Ramp Mount - Weld/Bolt On

A ramp mount weld on application is used when adequate dock steel is securely anchored in the concrete at the dock edge, but the existing dock height is too low and the dock leveler must be installed above this height to correct this situation.

Installation Steps:

1. Remove all existing bumper material and protruding objects from dock edge. Clean and sweep dock edge free of debris and flammable chemicals before installing unit.
2. At chosen location for Edge of Dock leveler, locate the center of space and mark a point half of the base plate width to the left and right.
3. At the points marked to each side of center, measure and mark points 7 - 3/4" below dock level less height the unit is to be raised to locate bottom of base plate. This will locate the top of the base plate X" above dock level.
4. Using a proper lifting device, raise and position the leveler base plate to marked position. While holding base plate tight against dock face, tack weld securely to dock steel on left hand end of leveler. Check right hand end of base plate, ensure that end is against dock steel and that the bottom of the base plate is even with the marks made previously. Tack right hand end to dock steel. Support unit until final welding is ready to complete.
5. Position bump blocks out approximately 5/8" out from the edge of the inside flange of the bump block to the end of the base plate. Position the top of the tread cover plate on the bump blocks to be flush with the top of the base plate. Tack weld bump blocks to dock steel.
6. Place steel ramp plate in position, flush with top backside of base plate. Mark along full length of back edge of ramp plate. Slide ramp plate forward over dock leveler the width of bushing tool, approximately 2".
7. Place brushing tool on marked line at each end of ramp to ensure proper alignment at both ends, and tack weld ramp plate to dock leveler to hold ramp plate in place while bushing. A Skil Roto Hammer #736 or similar tool is recommended.
8. Using the back edge of the ramp plate as a guide, groove concrete approximately 3/4" deep by 2" wide, and should be the entire length of ramp plate.
9. Break tack welds holding ramp in place, slide ramp plate back into position with the top of the ramp plate flush with the top of the base plate. Tack weld each end and center of ramp plate to base plate.
10. Drill 5/8" dia. by 5" deep holes through ramp plate at back edge. Install anchor bolts per manufacturers specifications, and tighten securely. Weld anchor bolt nuts to ramp plate using a 1/4" fillet weld all the way around the nut. Cut off any portion of the anchor bolt exposed through the nut, and plug weld around the top of the nut to the anchor bolt. Ensure the top of the nuts are well rounded for smooth rollover.
11. Complete welding of tacked parts as follows:
 - A. Apply continuous weld across top of each bumper and base plate to ramp plate. Skip welding is acceptable to prevent warpage, but complete weld must be completed.
 - B. Weld vertically along each end of base plate and on both inboard and outboard flanges of bump blocks.
 - C. Fully plug weld all holes in base plate.
12. Installer must remove all welding slag, and repaint welded areas.
13. Installer must adjust main springs on all mechanical edge of dock levelers to provide desired tension for smooth operation. Stand on ground in front of leveler, with the unit raised and secured in the maintenance position, loosen jam nut on the underside of the linkage pin. To start allow about 3/4" to 1" of threads between top of jam nut and linkage pin. Using an open faced wrench, hold locknut on inside of spring while tightening threaded bolt until washer on top side of spring closes up tight to jam nut. Test operation of unit. Further adjust spring tension if needed by advancing jam nut toward linkage pin and tightening threaded rod. After desired unit operation is achieved, tighten jam nut to outer washer on spring. Springs must be adjusted alternately to have equal spring tension.
14. Before install is complete, installer must make a final operational check of dock leveler to verify all phases of install are correct. Installer must complete, sign, and return the Installation Checklist upon completion.

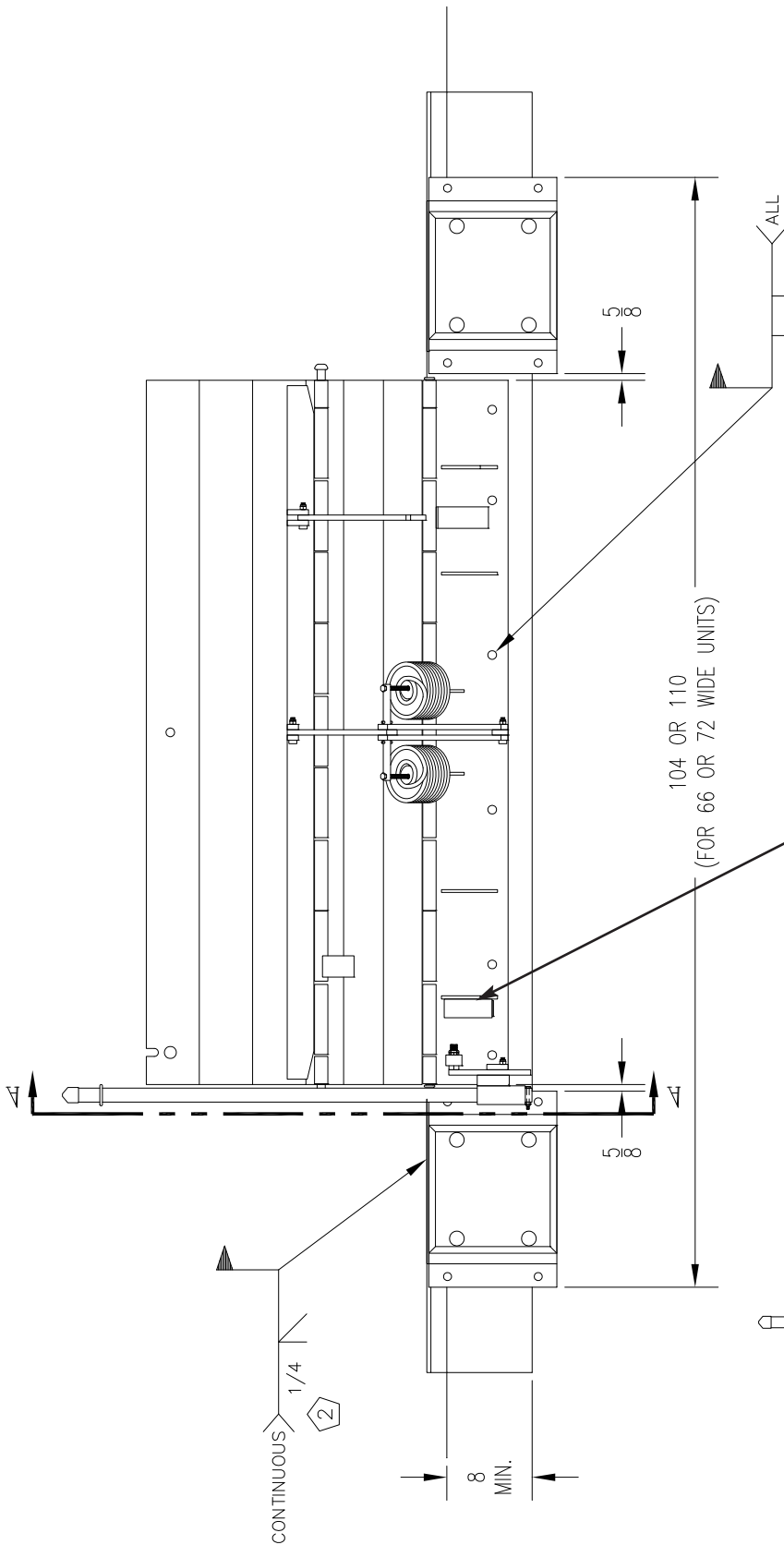

NOTE	DESCRIPTION
1	Top of base plate and bumper cover plate to be flush with top of ramp plate.
2	Apply continuous bevel weld across both bumpers and length of base plate.
3	To figure ramp plate length, need 12" ramp for every 1-1/2" of rise to ramp.

WARNING

Securely block or support ramp and lip when in vertical positions. Lack of proper bracing can result in ramp dropping during adjustment or installation causing personal injury or damage to unit.

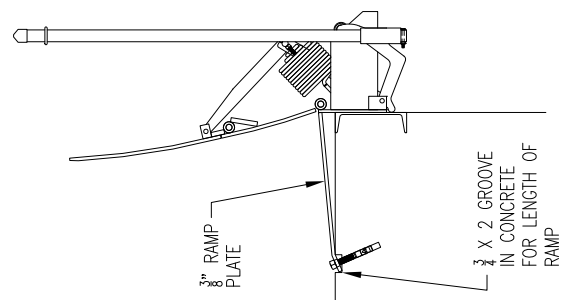

INSTALLATION

E.O.D. Installation Instructions Flush Mount - Bolt On

A flush mount bolt on application is used when there is no steel on dock edge, and the dock height is adequate. Additional steel ramp plate and bolting is required with this type of installation.

Installation Steps:

1. Remove all existing bumper material and protruding objects from dock edge. Clean and sweep dock edge free of debris and flammable chemicals before installing unit.
2. At chosen location for Edge of Dock leveler, locate the center of space and mark a point half of the base plate width to the left and right.
3. At the points marked to each side of center, measure and mark points 7-1/2" below dock level (for 1/4" ramp plate) to locate position for bottom of base plate. This position will place the top of the base plate 1/4" above the dock floor. This position will vary with ramp plate thickness.
4. Mark line connecting these points and position support angles. Position angles as shown in installation drawing provided. mark center of holes in each of the support angles.
5. At center marks, drill holes 5/8" dia. by 5" deep in concrete. Install anchor bolts with washers through support angles into holes in concrete. Tighten bolts until support angles are secure. Follow anchor manufacturers installation instructions for proper installation.
6. Using a proper lifting device, raise and position the leveler base plate to marked position, while resting on the support angles. While holding base plate tight against dock face, tack weld securely to support angles.
7. Drill 5/8" dia. by 5" deep holes in concrete through holes in base plate, and install anchor bolts with washers and tighten securely.
8. Position bump blocks out approximately 5/8" out from the edge of the inside flange of the bump block to the end of the base plate. Position the top of the tread cover plate on the bump blocks to be 1/4" above dock level. Note that this placement will vary with ramp plate thickness. Mark centers of holes in bump block flanges.
9. Drill 5/8" dia. by 5" deep holes at center marks. Reposition bump blocks, insert anchor bolts with washers and tighten securely to dock face.
10. Place steel ramp plate in position, flush with top backside of base plate. mark along full length of base edge of ramp plate. Slide ramp plate forward over dock leveler the width of brushing tool, approximately 2".
11. Place brushing tool on marked line at each end of ramp to ensure proper alignment at both ends, and tack weld ramp plate to dock leveler to hold ramp plate in place while brushing. A Skil Roto Hammer #736 or similar tool is recommended.
12. Using the back edge of the ramp plate as a guide, groove concrete approximately 5/8" deep by 2" wide, and should be the entire length of ramp plate.
13. Break tack welds holding ramp in place, slide ramp plate back into position with the top of the ramp plate flush with the top of the base plate. Tack weld each end and center of ramp plate to base plate.
14. Drill 5/8" dia. by 5" deep holes through ramp plate at back edge. Install anchor bolts per manufacturers specifications, and tighten securely. Weld anchor bolt nuts to ramp plate using a 1/4" fillet weld all the way around the nut. Cut off any portion of the anchor bolt exposed through the nut, and plug weld around the top of the nut to the anchor bolt. Ensure the top of the nuts are well rounded for smooth rollover.
15. Complete welding of tacked parts as follows:
 - A. Apply continuous weld across top of each bumper and base plate to ramp plate. Skip welding is acceptable to prevent warpage, but complete weld must be completed.
 - B. Weld bottom of base plate support angles using a 1/4" fillet weld.
16. Installer must remove all welding slag, and repaint welded areas.
17. Installer must adjust main springs on all mechanical edge of dock levelers to provide

desired tension or smooth operation. Stand on ground in front of lever, with the unit raised and secured in the maintenance position, loosen jam nut on the underside of the linkage pin. To start allow about 3/4" to 1" of threads between top of jam nut and linkage pin. Using an open faced wrench, hold locknut on inside of spring while tightening threaded bolt until washer on top side of spring closes up tight to ram nut. Test operation of unit. Further adjust spring tension if needed by advancing jam nut toward linkage pin and tightening threaded rod. After desired until operation is achieved, tighten jam nut to outer washer on spring. Springs must be adjusted alternately to have equal spring tension.

18. Before install is complete, installer must make a final operation check of dock leveler to verify all phases of install are correct. Installer must complete, sign and return the Installation Checklist up on completion.

⚠ WARNING

Securely block or support ramp and lip when in vertical positions. Lack of proper bracing can result in ramp dropping during adjustment or installation causing personal injury or damage to unit.

NOTE	DESCRIPTION
1	Top of base plate and bumper cover plate to be flush with top of ramp plate.
2	Apply continuous bevel weld across both bumpers and length of base plate.

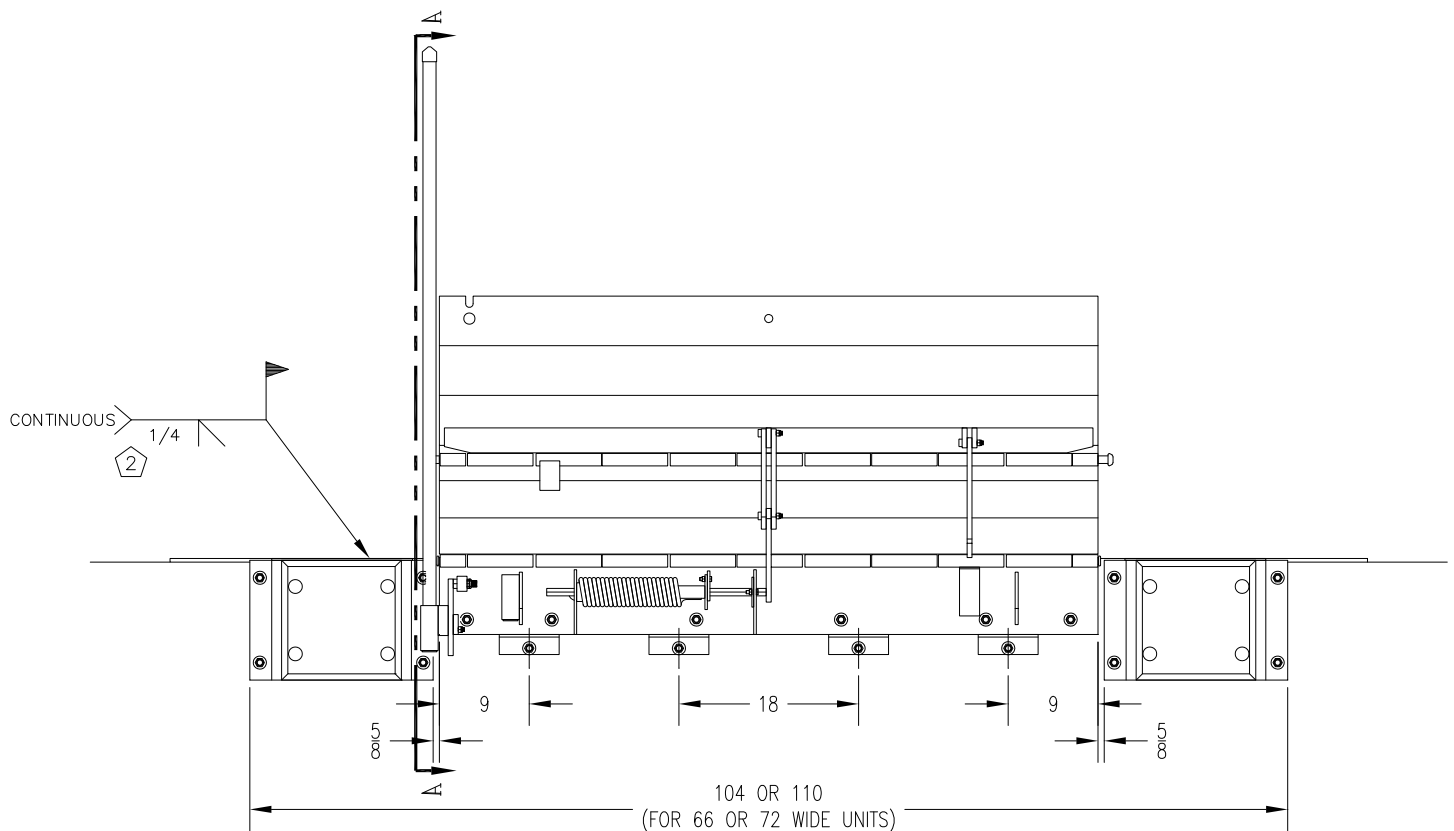

INSTALLATION

E.O.D. Installation Instructions Ramp Mount - Weld On w/Formed Angle

A ramp mount-weld on used with a formed angle application is used when dock edge is damaged, there is no dock steel securely anchored into the concrete, and the dock height is too low and leveler must be installed above this height to correct this situation.

Installation Steps:

1. Remove all existing bumper material and protruding objects from dock edge. Clean and sweep dock edge free of debris and flammable chemicals before installing unit.
2. Review and follow formed angle installation instructions prior to leveler installation.
3. At chosen location for Edge of Dock leveler, locate the center of space and mark a point half of the base plate width to the left and right.
4. At the points marked to each side of center, measure and mark points 7-3/4" below dock level less height the unit is to be raised to locate bottom of base plate. This will locate the top of the base plate "X" above dock level.
5. Using a proper lifting device, raise and position the leveler base plate to marked position. While holding base plate tight against dock face, tack weld securely to dock steel on left hand end of leveler. Check right hand end of base plate, ensure that end is against dock steel and that the bottom of the base plate is even with the marks made previously. Tack right hand end to dock steel. Support unit until final welding is ready to complete.
6. Position bump blocks out approximately 5/8" out from the edge of the inside flange of the bump block to the end of the base plate. Position the top of the tread cover plate on the bump blocks to be flush with the top of the base plate. Tack weld bump blocks to dock steel.
7. Place steel ramp plate in position, flush with top backside of base plate. Mark along full length of back edge of ramp plate. Slide ramp plate forward over dock leveler the width of bushing tool, approximately, 2".
8. Place bushing tool on marked line at each end of ramp to ensure proper alignment at both ends, and tack weld ramp plate to dock leveler to hold ramp plate in place while bushing. A Skil Roto Hammer #736 or similar tool is recommended.
9. Using the back edge of the ramp plate as a guide, groove concrete approximately 3/4" deep by 2" wide, and should be the entire length of ramp plate.
10. Break tack welds holding ramp in place, slide ramp plate back into position with the top of the ramp plate flush with the top of the base plate. Tack weld each end and center of ramp plate to base plate.
11. Drill 5/8" dia. by 5" deep holes through ramp plate at back edge. Install anchor bolts per manufacturers specifications, and tighten securely. Weld anchor bolt nuts to ramp plate using a 1/4" fillet weld all the way around the nut. Cut off any portion of the anchor bolt exposed through the nut, and plug weld around the top of the nut to the anchor bolt. Ensure the top of the nuts are well rounded for smooth rollover.
12. Complete welding of tacked parts as follows:
 - A. Apply continuous weld across top of each bumper and base plate to ramp plate. Skip welding is acceptable to prevent warpage, but complete weld must be completed.
 - B. Weld vertically along each end of base plate and on both inboard and outboard flanges of bump blocks.
 - C. Fully plug weld all holes in base plate.
13. Installer must remove all welding slag, and repaint welded areas.
14. Installer must adjust main springs on all mechanical edge of dock levelers to provide desired tension for smooth operation. Stand on ground in front of leveler, with the unit raised and secured in the maintenance position, loosen jam nut on the underside of the linkage pin. To start allow about 3/4" to 1" of threads between top of jam nut and linkage pin. Using an open faced wrench, hold locknut on inside of spring while tightening threaded bolt until washer on top side spring closes up tight to jam nut. Test operation of unit. Further adjust spring tension if needed by advancing jam nut toward linkage pin and tightening threaded rod. After desired unit operation is achieved, tighten jam nut to outer washer on spring. Springs must be adjusted alternately to have equal spring tension.
15. Before install is complete, installer must make a final operational check of dock leveler to verify all phases of install are correct. Installer must complete, sign, and return the Installation upon completion.

INSTALLATION

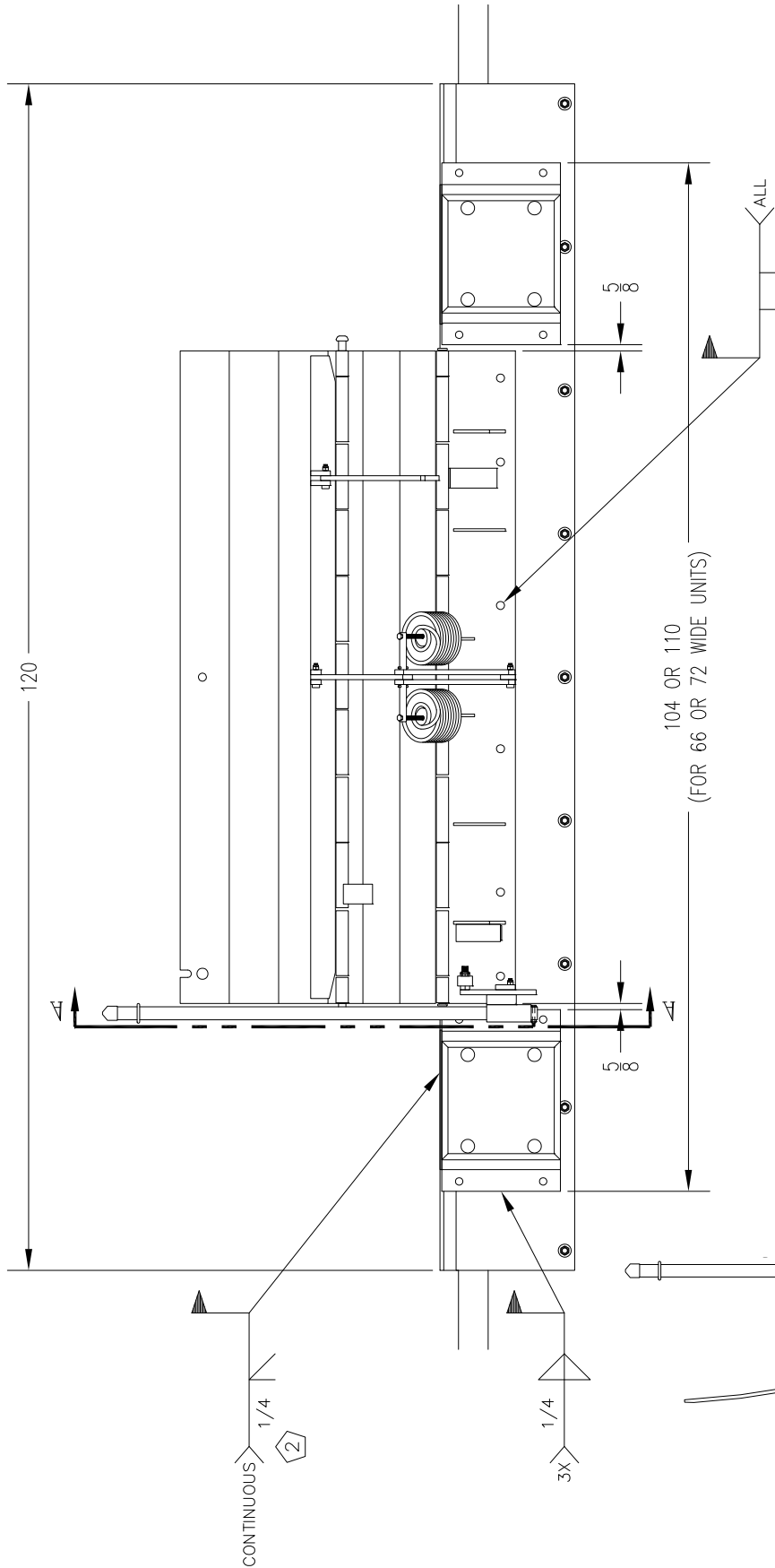

NOTE	DESCRIPTION
1	Top of base plate and bumper cover plate to be flush with top of ramp plate.
2	Apply continuous bevel weld across both bumpers and length of base plate.
3	To figure ramp plate length, need 12" ramp for every 1-1/2" of rise to ramp.
4	To install formed angle, see formed angle installation instructions.

WARNING

Securely block or support ramp and lip when in vertical positions. Lack of proper bracing can result in ramp dropping during adjustment or installation causing personal injury or damage to unit.

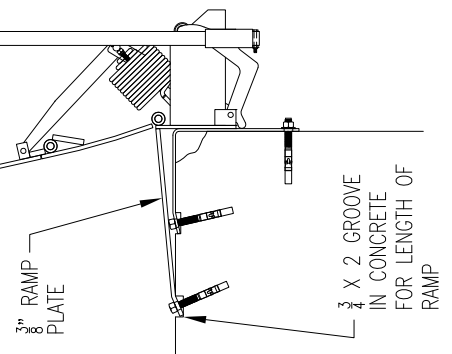

INSTALLATION

E.O.D. Installation Instructions Formed Angle

A formed angle is used when there is no existing dock steel and concrete at the dock edge has been damaged. The formed angle is required to rebuild the damaged concrete edge for a proper installation if the dock height is adequate.

Installation Steps:

1. Remove all existing bumper material and protruding objects from dock edge. Clean and sweep dock edge free of debris and flammable chemicals before installing unit.
2. At chosen location for the formed angle, locate the center of space and mark a point half of the angle width to the left and right.
3. Using a proper lifting device, raise and position the formed angle to marked position, slide formed angle against dock face.
4. Mark along full length of back edge of formed angle. Slide angle forward the width of brushing tool, approximately 2".
5. Place brushing tool on marked line at each end of formed angle to ensure proper alignment at both ends. A Skil Roto Hammer #736 or similar tool is recommended.
6. Using the back edge of the formed angle as a guide, groove concrete approximately 5/8" deep by 2" wide, and should be the entire length of the formed angle.
7. Slide formed angle back until tight against dock face. drill 5/8" dia. by 5" deep holes through formed angle at back edge. Install anchor bolts per manufacturers specifications, and tighten securely. Weld anchor bolt nuts to formed angle using a 1/4" fillet weld all the way around the nut. Cut off any portion of the anchor bolt exposed through the nut, and plug weld around the top of the nut to the anchor bolt. Ensure the top of the nuts are well rounded for smooth rollover.
8. Drill 5/8" dia. by 5" deep holes in dock face through holes in formed angle. Install anchor bolts with washers and tighten securely per manufacturers specifications.

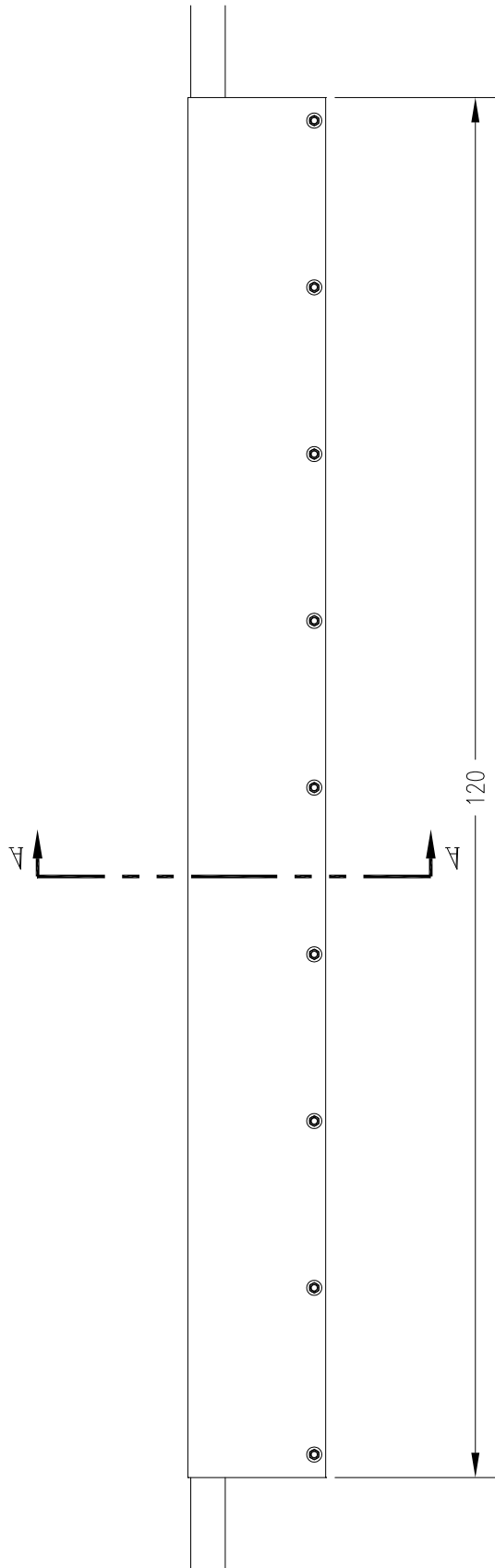

BREAK IN
FORMED ANGLE

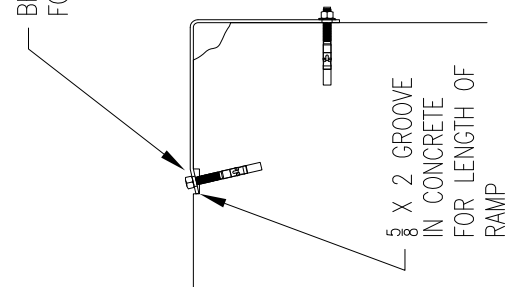

NOTE	DESCRIPTION
1	Secure formed angle with (18) anchor bolts, (9) each side

INSTALLATION

E.O.D. Installation Instructions Ramp and Face Plate

A ramp mount requiring a face plate application is used when there is no existing dock steel and the concrete at the dock edge has been damaged. The dock height can be low, high, or adequate for this application, however, the face plate and ramp plate are required to rebuild the damaged concrete edge.

Installation Steps:

1. Remove all existing bumper material and protruding objects from dock edge. Clean and sweep dock edge free of debris and flammable chemicals before installing unit.
2. At chosen location for the face plate, locate the center of space and mark a point half of the face plate width to the left and right.
3. Using a proper lifting device, raise and position the face plate to marked position, and push face plate against dock face.
4. Top of face plate should be flush with the top of dock floor. mark center of holes in face plate into dock face. Drill 5/8" dia. by 5" holes into dock face. Install anchor bolts with washers per manufacturers specifications and tighten securely.
5. Place ramp plate to match each end of the face plate. leading (forward) edge of ramp plate should be flush with dock face.
6. Mark along full length of back edge of ramp plate. Slide ramp forward the width of bushing tool, approximately 2".
7. Place bushing tool on marked line at each end of ramp to ensure proper alignment at both ends. A Skil Roto Hammer #736 or similar tool is recommended.
8. Tack weld ramp to face plate on each end to secure in place.
9. Using the back edge of the ramp plate as a guide, groove concrete approximately 5/8" deep by 2" wide, and should be the entire length of the ramp plate.
10. Break tack welds and slide ramp back until forward edge is flush with dock face. Tack weld ramp on each end and center to face plate. Drill 5/8" dia. by 5" deep holes through ramp plate at back edge. Install anchor bolts per manufacturers specifications, and tighten securely. Weld anchor bolt nuts to ramp plate using a 1/4" fillet weld all the way around the nut. Cut off any portion of the anchor bolt exposed through the nut, and plug weld around the top of the nut to the anchor bolt. Ensure the top of the nuts are well rounded for smooth rollover.
11. Apply a continuous fillet weld at the created joint between the face plate and ramp. Skip welding should be the proper method used to avoid warpage, and a complete weld must be achieved.

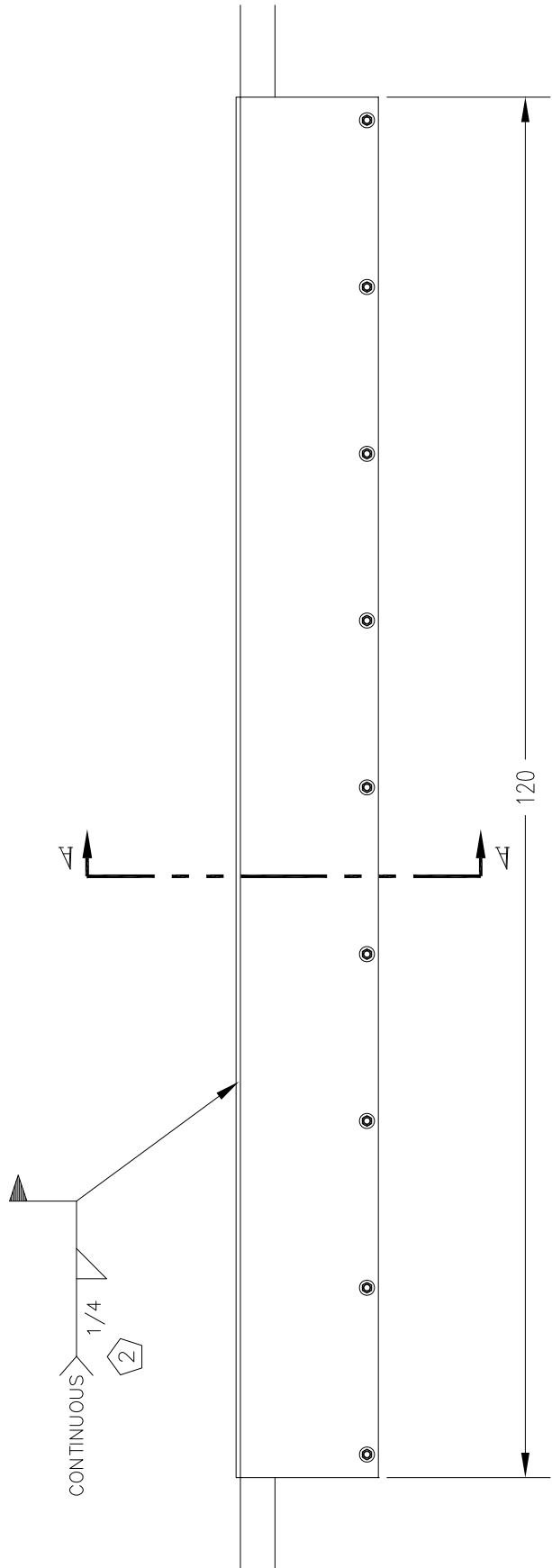

TOP OF FACE PLATE FLUSH WITH TOP OF DOCK FLOOR. LEADING EDGE OF RAMP PLATE FLUSH WITH DOCK FACE.

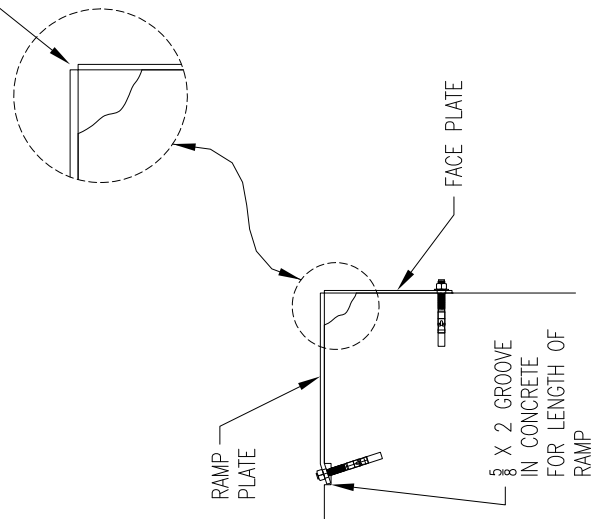

NOTE	DESCRIPTION
1	Secure formed angle with (18) anchor bolts, (9) each side
2	Apply continuous fillet weld across entire length of face plate and ramp

INSTALLATION - CHECKLIST



Date: _____ Order No.: _____ Serial Number: _____

Installer: _____

Customer Name: _____

Address: _____

City/State: _____ Zip: _____

Phone: _____

1. Unit is properly aligned and installed properly.
2. All welding has been fully completed.
3. Welding slag has been removed.
4. Welds and other affected areas have been painted.
5. Springs have been properly adjusted.
6. Unit is functioning properly without fault.

I hereby certify that all installation and/or repair work has been inspected and approved by:

Company: _____ Date Completed: _____

Name: _____ Signature: _____

A copy of this document must be signed and faxed to Systems, Inc at 262-257-7399 to the attention Customer Service/ Technical Service. To be placed in job folder.
Copy as needed

OPERATING INSTRUCTIONS

1. Grasp the captured operating handle and raise to its full extended length.
2. Move handle toward you, rotating center plate back past vertical. Lip plate extend link stop will engage at this time.
3. Push forward on operating handle rotating leveler out onto truck.
4. Return handle to stored position.
5. To remove leveler from truck repeat step number one, until lip plate is clear of the truck. Return leveler and handle to the stored position.



WARNING

Only trained personnel should operate the dock leveler.

DO NOT use a broken or damaged dock leveler. Make sure proper service and maintenance procedures have been performed on leveler before using.

Truck/trailer wheels must be chocked unless the truck restraint is used. Never remove the wheel chocks until loading/unloading is finished and truck driver has been given permission to leave.

Make sure platform lip rests on the truck/trailer bed with at least 4 in. (102 mm) of overlap.

Maintain a safe distance from side edges of leveler during the loading/unloading process.

Failure to follow these instructions may result in serious personal injury or death.

DANGER

Stay clear of dock leveler when freight carrier is entering or leaving dock area.

DO NOT move or use the dock leveler if anyone is under or in front of leveler.

Keep hands and feet clear of pinch points. Avoid putting any part of your body near moving parts.

Failure to follow these instructions may result in severe personal injury or death.

MAINTENANCE

Whenever maintenance is to be performed in front of the dock leveler, support the lip with the handle in the maintenance prop position.

Put handle into maintenance prop position by removing bolt and locknut at base of handle assembly. Pull handle out of roller arm assembly and place into maintenance prop receiver.

If maintenance requires that the lip be in the extended position, raise the lip by hand and support the lip with the lip maintenance prop.

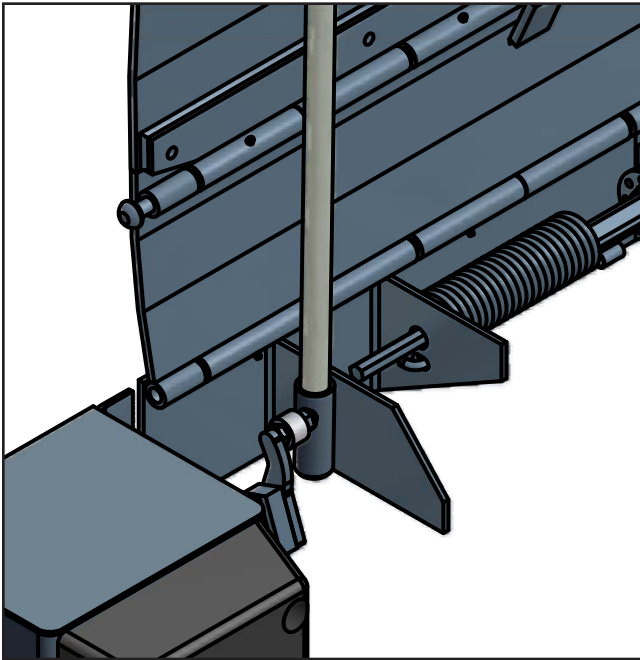

Regular maintenance must be performed on a weekly and quarterly schedule.

Weekly Maintenance

- Operate the dock leveler through the complete operating cycle to maintain lubrication.
- Inspect the platform hinge and the lip hinge areas. The hinge areas must be kept free of dirt and debris. Build-up of foreign material in the hinge areas will increase wear and cause abnormal operation.

WARNING

Always post safety warnings and barricade the work area at dock level and ground level to prevent unauthorized use of the dock leveler before maintenance is complete. Failure to do this may result in serious personal injury or death.

WARNING

Always stand clear of the dock leveler lip when working in front of the dock leveler. Failure to do this may result in serious personal injury or death.

WARNING

Securely block or support ramp and lip when in vertical position. Lack of proper bracing can result in ramp dropping during maintenance causing personal injury or damage to unit.

Quarterly Maintenance

- Lubricate the following areas with light-weight machine oil:
 - Extend link arm pivots
 - Lip linkage pivot
 - Operating link pivots
 - Torsion arm pivots
- Lubricate the following areas with white lithium grease:
 - Lip plate grease fittings
 - Center plate grease fittings (Ref, Page7.)

Note: Failure to lubricate the dock leveler will cause abnormal operation of the leveler.

TROUBLESHOOTING

Symptom	Possible Cause	Solution
Unit does not operate properly	Debris impacted on or around the leveler	Clean out debris on or around leveler
	Insufficient lubrication	Lubricate unit
	Excessive weight on top of deck	Remove weight from deck.
	Main spring tension	Adjust tension, more or less for proper operation
Extended link arm does not latch out lip or unlatch	Debris impacted in extended link arm	Clean out debris from extended link arm
	Extended link arm needs lubrication	Lubricated extended link arm

PARTS

MEDLF Series

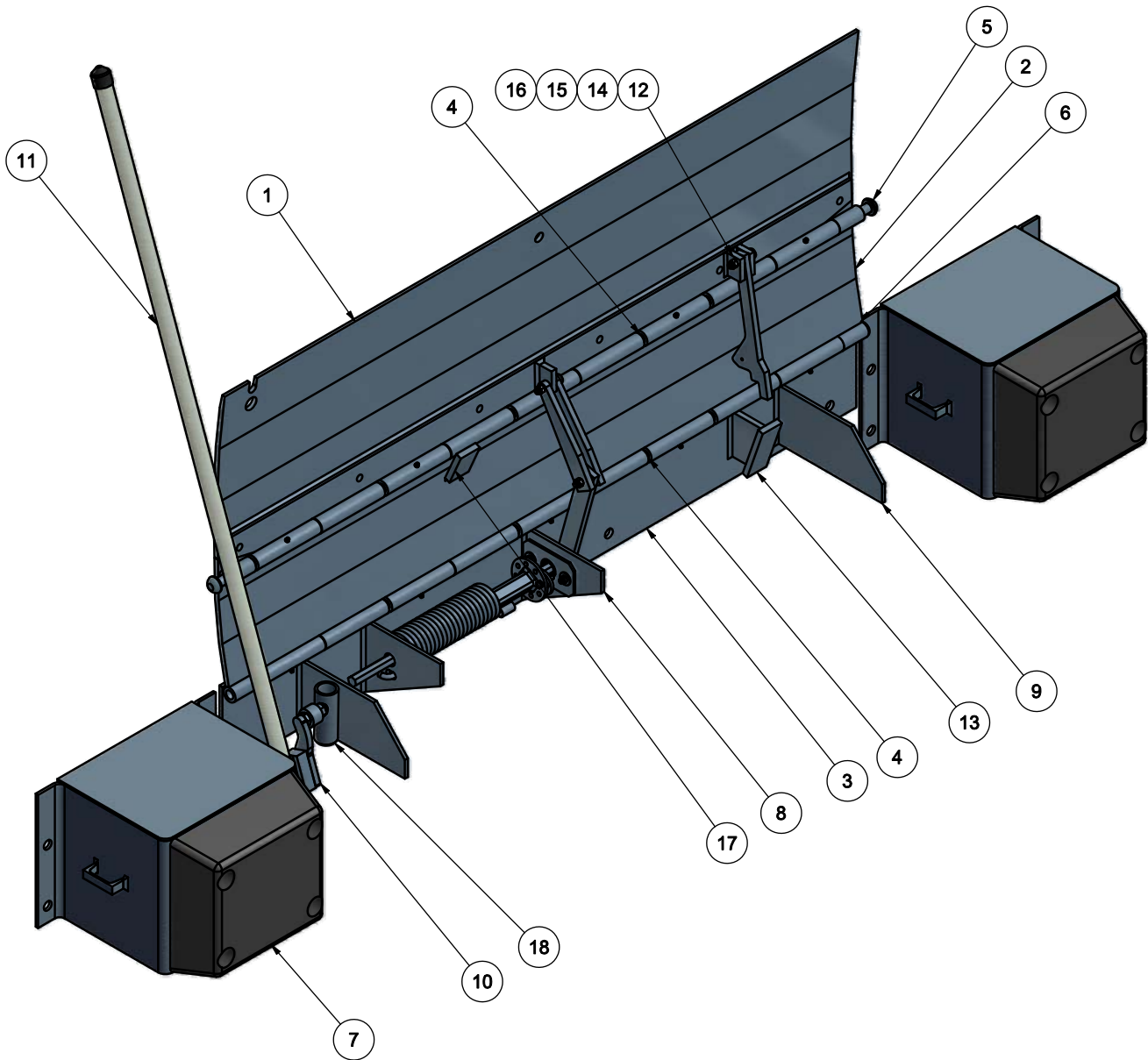

MEDLF Model Edge of Dock

ITEM	QTY	Size/Capacity	Description	Part Number (15" Lip)	Part Number (17" Lip)
1	1	6620/25	Lip Plate & Hinge Assembly	DOTH-4068	DOTH-4069
1	1	6630	Lip Plate & Hinge Assembly	DOTH-4070	DOTH-4071
1	1	6635	Lip Plate & Hinge Assembly	DOTH-4072	DOTH-4073
1	1	7220/25	Lip Plate & Hinge Assembly	DOTH-4074	DOTH-4075
1	1	7230	Lip Plate & Hinge Assembly	DOTH-4076	DOTH-4077
1	1	7235	Lip Plate & Hinge Assembly	DOTH-4078	DOTH-4079
1	1	7820/25	Lip Plate & Hinge Assembly	DOTH-4080	DOTH-4081
1	1	7830	Lip Plate & Hinge Assembly	DOTH-4082	DOTH-4083
1	1	8420/25	Lip Plate & Hinge Assembly	DOTH-4084	DOTH-4085
1	1	8430	Lip Plate & Hinge Assembly	DOTH-4086	DOTH-4087
2	1	6620/25	Center Plate & Hinge Assembly	DOTH-4088	
2	1	6630	Center Plate & Hinge Assembly	DOTH-4089	
2	1	6635	Center Plate & Hinge Assembly	DOTH-4090	
2	1	7220/25	Center Plate & Hinge Assembly	DOTH-4091	
2	1	7230	Center Plate & Hinge Assembly	DOTH-4092	
2	1	7235	Center Plate & Hinge Assembly	DOTH-4093	
2	1	7820/25	Center Plate & Hinge Assembly	DOTH-4094	
2	1	7830	Center Plate & Hinge Assembly	DOTH-4095	
2	1	8420/25	Center Plate & Hinge Assembly	DOTH-4096	
2	1	8430	Center Plate & Hinge Assembly	DOTH-4097	
3	1	All	Base Plate & Hinge Assembly	Consult Factory	
4	2	6620/25/30	Hinge Pin	DOTH-3104	
4	2	6635	Hinge Pin	DOTH-4312	
4	2	7220/25/30	Hinge Pin	DOTH-3122	
4	2	7235	Hinge Pin	DOTH-4313	
4	2	7820/25/30	Hinge Pin	DOTH-3946	
4	2	8420/25/30	Hinge Pin	DOTH-3920	
5	2	All	Rivet - Button	DOTH-2400	
6	2	All	Rivet - Flat	DOTH-2398	
7	2	All	Extra Hvy Duty Bumper Blocks	DBBS-3519	
8	1	All	HL Linkage Adder Assembly	DOTH-3675	
9	2	All	X-Gusset	DOTH-3589	
10	1	All	NLIII Operating Link Assembly	DOTH-3696	
10	1	35K	NLIII Operating Link Assembly	DOTH-3697	
11	1	All	NLIII Handle Assembly	DOTH-3694	
12	1	All	Extend Link Arm	DOTH-3585	
13	1	All	Extend Link Arm Stop	DOTH-3586	
14	2	All	Pivot Block	DOTH-3316	
15	1	All	Shoulder Bolt	DOTH-2061	
16	1	All	Locknut	DOTH-2136	
17	1	All	Lip Stop	DOTH-3734	
18	1	All	NLIII Handle Holder	DOTH-3695	

PARTS

BILL OF MATERIAL				
ITEM	QTY	PART NO.	DESCRIPTION	SIZE
1	1	DOTH-3305	L&R GUSSET ASSEMBLY W/BEARING	
2	1	DOTH-3327	HL MODEL GUSSET W/GUIDE	
3	1	DOTH-3679	HL TORSION TUBE ASSY	
4	1	DOTH-3676	HL TORSION BAR ASSEMBLY	
5	1	DOTH-2509	SPRING - TORSION	0.422 DIA WIRE X 2-15/16 OD X 13-5/16 LG.
6	1	DOTH-3316	BAR - PIVOT	1/2 X 1-1/2 X 2
7	3	DOTH-2033	HHCS - GRADE 2 - ZINC PLATED	5/16-18 UNC X 1-1/4
8	1	DOTH-2121	NYLON LOCK NUT	5/16-18 UNC
9	1	DOTH-3682	HL PLATE LOCKING TORSION	3/8 X 2 X 3
10	2	DOTH-3617	BAR - 6630 L-LINKAGE	1/2 X 1-1/2 X 8-3/4
11	2	DOTH-2061	1-1/2" SHOULDER BOLT	1/2 X 1-1/2
12	2	DOTH-2136	CENTER LOCKNUT	3/8-16

Torsion Spring Adjustment Instructions:

- 1) Lift and secure leveler in full upright maintenance position to start.
- 2) Remove nut (A) from hex bolt (B).
- 3) Place crescent wrench on torsion tube assembly, apply enough downward force to tube assembly until hex bolt can be removed.
- 4) Continue to apply downward force until flange on tube assembly has the next hole in series come into alignment with hex bolt hole.
- 5) Insert hex bolt (B) through the flange on the tube assembly, and tighten nut until secure.
- 6) Test leveler operation. If spring tension is not sufficient, repeat the previous steps until desired tension is achieved.
- 7) Return leveler to stored position.

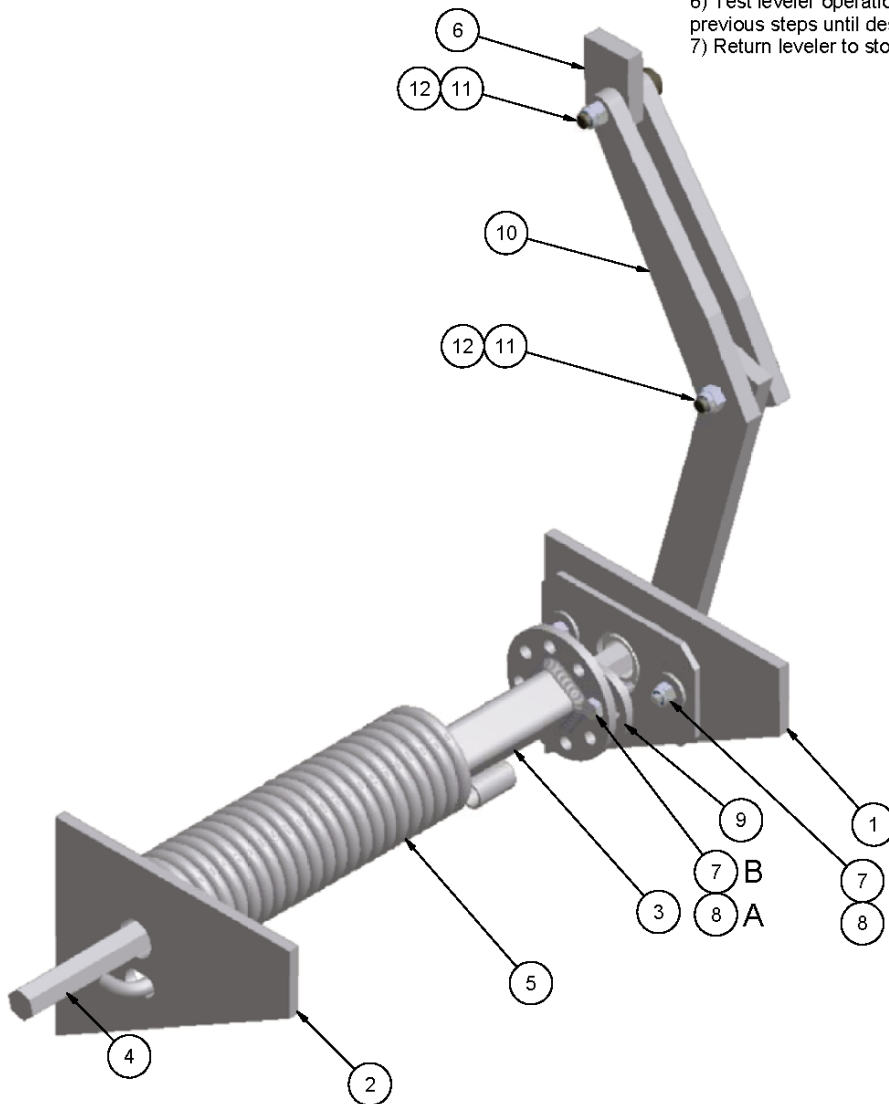

This page intentionally left blank

PARTS

BILL OF MATERIAL					
ITEM	QTY	PART NO.	DESCRIPTION	SIZE	
1	1	DOTH-3556	18" PROJ. X 12" BB WELDMENT (HED)		
2	1	DOTH-3505	RUBBER - TUF-CORD	4 X 12 X 13	
3	4	DOTH-2056	HEX HEAD CAP SCREW	7/16-14 UNC X 3-1/4	
4	4	DOTH-2210	WASHER - FLAT - ZINC PLATED	1/2" DIA	
5	4	DOTH-2208	WASHER - FLAT	1/2" DIA	
6	4	DOTH-2129	NYLON LOCK NUT	7/16-14 UNC	

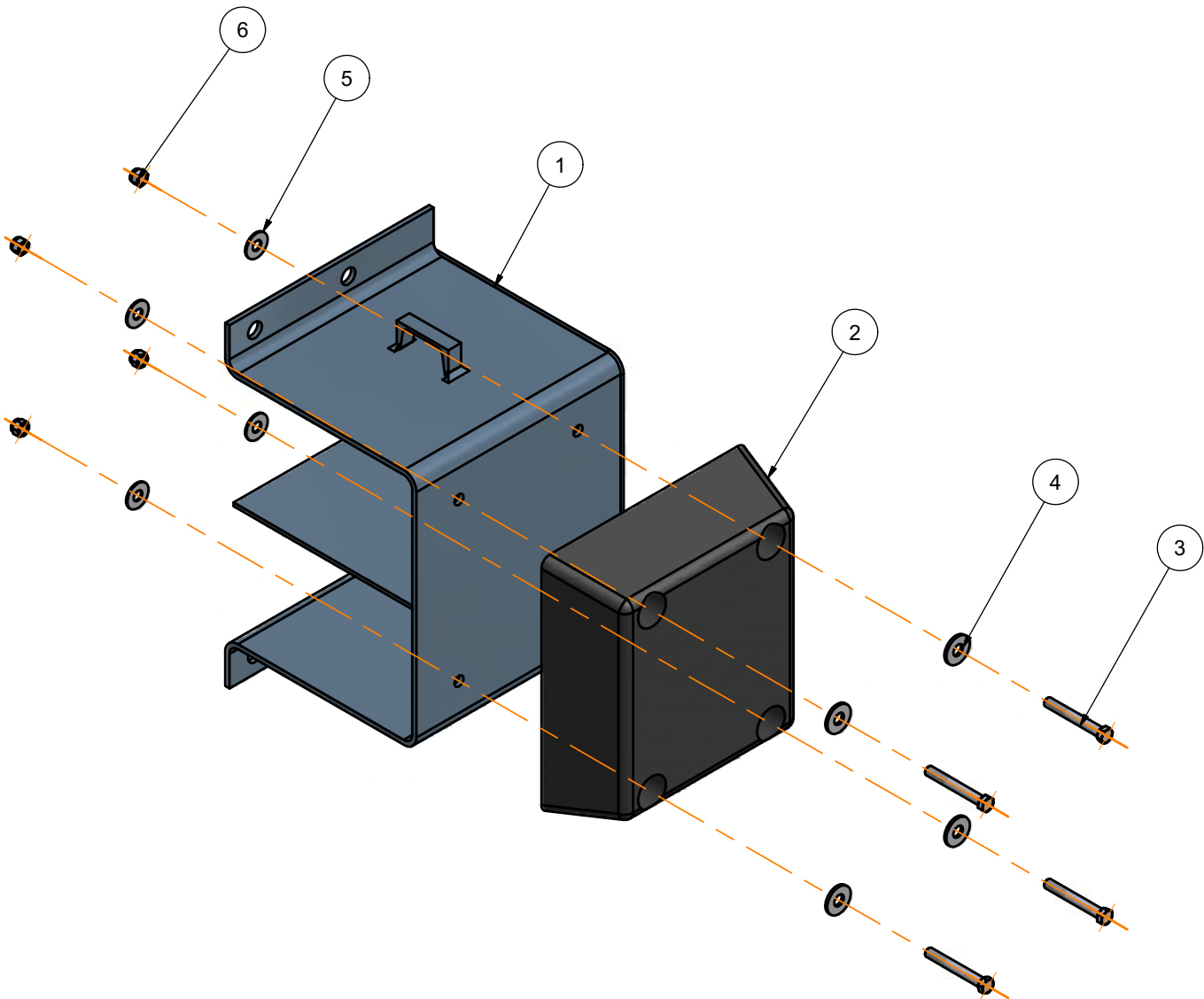

BILL OF MATERIAL				
ITEM	QTY	PART NO.	DESCRIPTION	SIZE
1	1	DOTH-3537	12" BB WELDMENT	
2	2	DOTH-3514	ANGLE - 12" BB SLIDE	
3	2	DOTH-3515	BAR - BB SLIDING STOP	
4	1	DOTH-3517	12" SLIDING BB PLATE W/RUBBER	

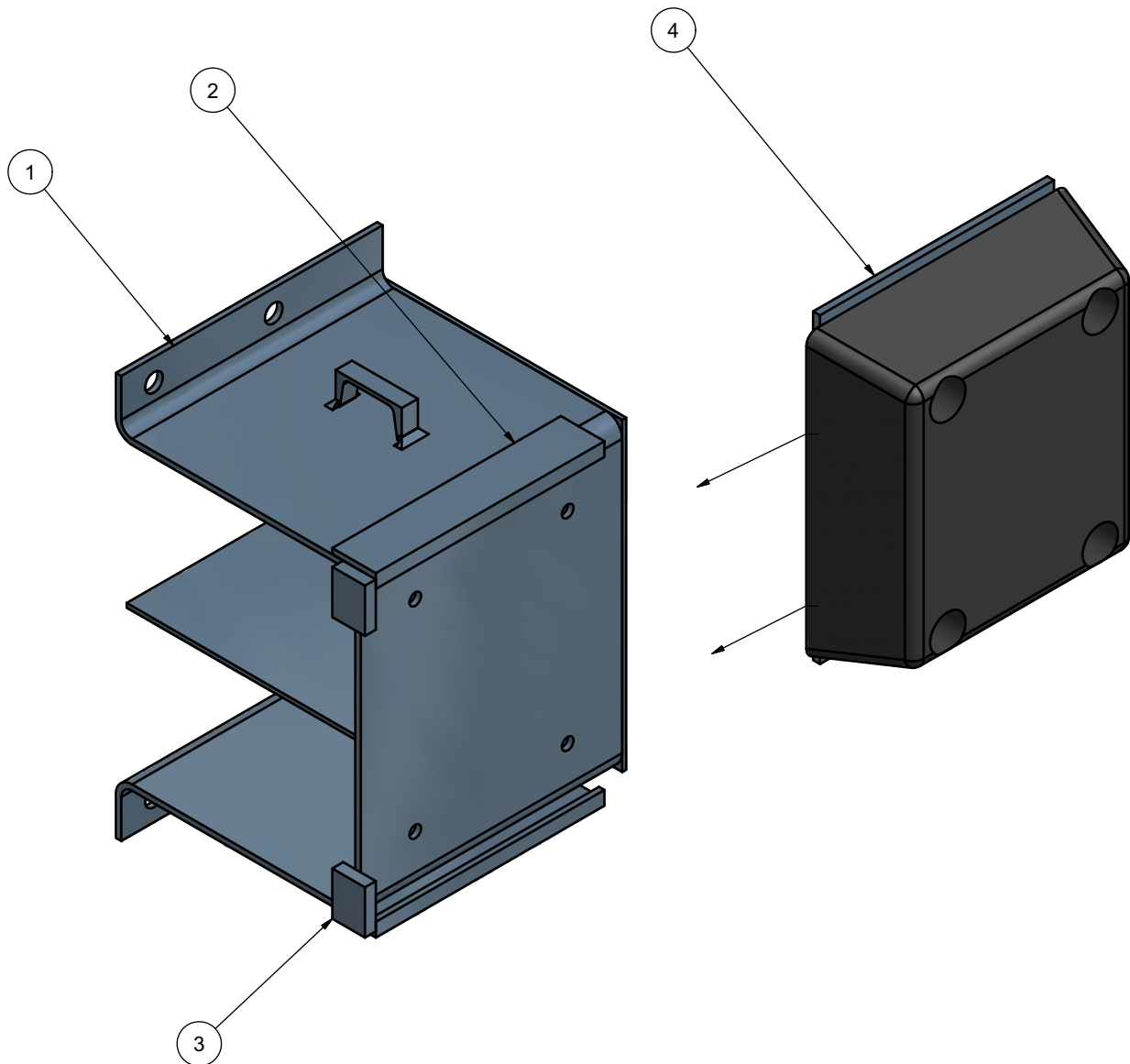

MISCELLANEOUS

This page intentionally left blank

MISCELLANEOUS

This page intentionally left blank

This page intentionally left blank

Customer Information

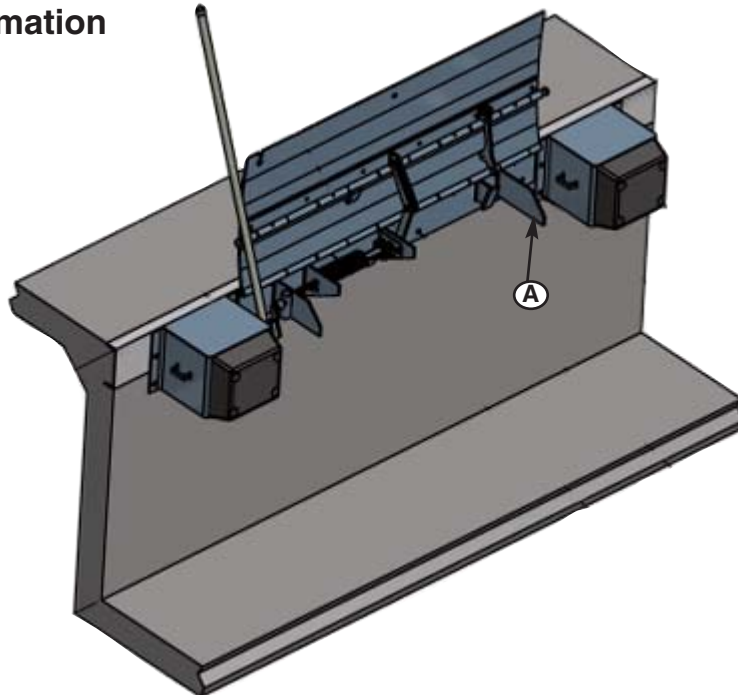

NOTE: The model/serial number decal (A) is located on the right platform joist near the front (lip) of dock leveler.

When you receive your MEDLF-series Edge-of-Dock leveler, write down the dock leveler model and serial number in the form provided. This will help ensure safe keeping of the numbers in the event the model/serial number decal (A) becomes lost or damaged.

Also, write down McGuire's job number, the company that installed the dock leveler, and the original owner's name. This will all help to identify the specific dock leveler if more information is required.

When ordering, use part numbers and description to help identify the item ordered. Do not use "item" numbers. These are only for locating the position of the parts. Always give dock leveler MODEL NUMBER and/or SERIAL NUMBER.

For service, call or contact:

Systems, Inc.
P.O. Box 309
Germantown, WI 53022

Phone: (800) 624-8473
Fax: (262) 255-5917

<u>Dock Leveler Information</u>	
Model	_____
Serial No.	_____
McGuire Job No.	_____
<u>Original Owner Information</u>	
Name	_____
Address	_____ _____
<u>Installer Information</u>	
Name	_____
Address	_____ _____
Date of Installation	_____

McGuire WARRANTY

MEDLF SERIES MECHANICAL EDGE-OF-DOCK LEVELER

McGuire, guarantees the materials, components, and workmanship in your McGuire MEDLF-Series Edge-of-Dock leveler to be of the highest quality and to be free of defects in material and workmanship for a full One (1) Year Base Warranty on all components. The Base Warranty includes replacement parts, labor, and freight.

Specifically, the structural warranty includes the lip, center and base plate assemblies.

McGuire, warrants all components to be free of defects in material and workmanship, under normal use, during the warranty period. This base warranty period begins upon the completion of the installation or the Sixtieth (60th) day after shipment, whichever is earlier.

All guarantee claims will be settled on a timely basis when defects are found to be from other than improper installation, operating contrary to instructions or beyond rated load capacities, abuse, careless or negligent use, or failure to maintain the unit as recommended by the owner's/user's manual.

There are no guarantees, either expressed or implied, including any implied guarantees of merchantability or fitness for a particular purpose which shall extend beyond the guarantee periods indicated above. This guarantee is valid only if the unit(s) is unaltered from original condition as delivered from the factory and a survey is completed by a McGuire representative.