

**TC500**  
FLEXIBLE FRAME WOOD  
DOCK SHELTER

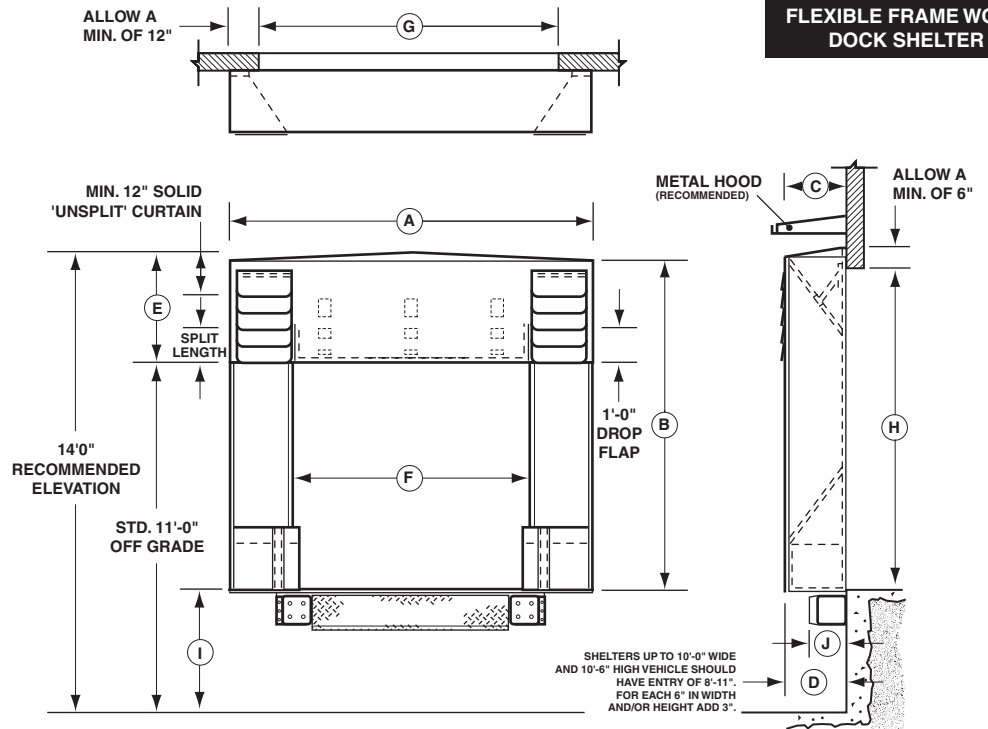

PLAN VIEW

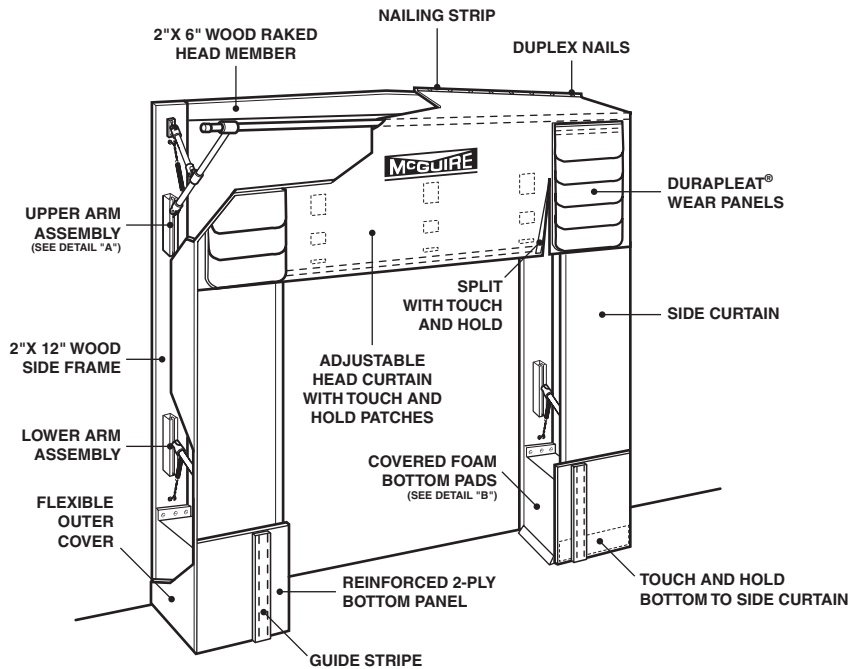
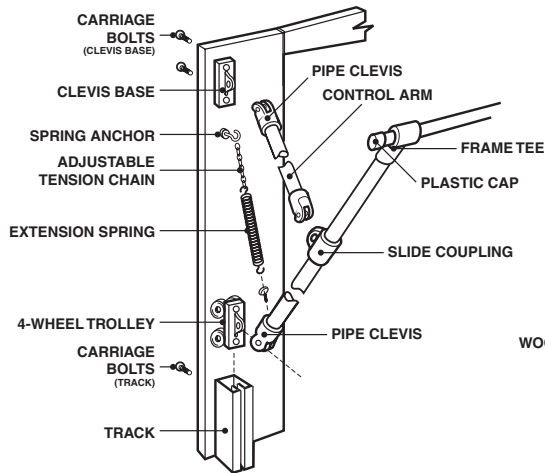

DETAIL "A"  
UPPER ARM ASSEMBLY

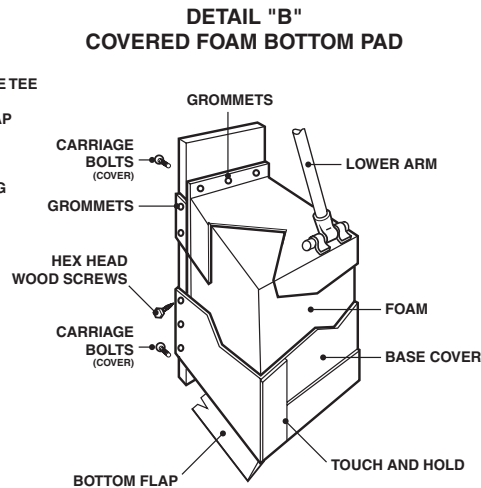

DETAIL "B"  
COVERED FOAM BOTTOM PAD

<p><b>UNIT DATA</b></p> <p>"A" SHELTER WIDTH (STD. 10'-6" THRU MAX. 11'-0")</p> <p>"B" SHELTER HEIGHT (MAX. 12'-0" REFER TO ABOVE)</p> <p>"C" TOP "D" BOTTOM SHELTER PROJECTION (15", 20" 25" AND MAX. 30" PROJ.)</p> <p>"E" HEAD CURTAIN LENGTH (INCLUDES STD. 1'-0" DROP FLAP)</p> <p>"F" SIDE CURTAIN I.D. (STD. 7'-3")</p> <p>DRIVE APPROACH: <input type="checkbox"/> LEVEL <input type="checkbox"/> DECLINED <input type="checkbox"/> INCLINED</p> <p><small>*IF AN INCLINED DRIVE REQUIRES A GREATER THAN 3" DIFFERENTIAL IN TOP AND BOTTOM PROJ. THIS SERIES SHELTER IS NOT SUITABLE.</small></p> <p>RISE OR FALL PER LENGTH OF DRIVE APPROACH</p> <p><b>GENERAL INFORMATION</b></p> <p>"G" DOOR WIDTH</p> <p>"H" DOOR HEIGHT</p> <p>"I" DOCK HEIGHT</p>	<p>"J" DOCK BUMPER/LEDGE COMBINED PROJ.</p> <p><small>(ON A LEVEL DRIVE APPROACH THERE MUST BE A MINIMUM OF 6" PROJ. OR 4" IF OPTIONAL RECESSED HARDWARE IS UTILIZED. THE PROJ. MUST BE INCREASED APPROPRIATELY FOR A DECLINED DRIVE APPROACH.)</small></p> <p>DISTANCE BETWEEN DOORS</p> <p>CLEARANCE ABOVE DOOR</p> <p>MIN. THRU MAX. HEIGHT OF VEHICLES TO BE SERVICED (INDICATE THE MAJORITY)</p> <p>DIM. OF VEHICLE'S REAR TAILGATE/ BUMPER EXTENSION AND APPROX. % TO BE SERVICED</p>	<p><b>FABRIC</b></p> <p><input type="checkbox"/> 22 OZ. VINYL ALL COLOR</p> <p><input type="checkbox"/> 16 OZ. HYPALON® BLACK</p> <p><b>OPTIONAL EQUIPMENT</b></p> <p><input type="checkbox"/> ROPE/PULLEY SYSTEM (HEAD CURTAIN)</p> <p><input type="checkbox"/> RECESSED HARDWARE</p> <p><input type="checkbox"/> NON-ROT WOOD PRESERVATIVE</p> <p><input type="checkbox"/> FORMED STEEL FRAME (MIN. 14 GAUGE)</p> <p><input type="checkbox"/> PAINTED <input type="checkbox"/> GALVANIZED</p>
<p><b>McGUIRE</b> 205 BROADVIEW STREET • P.O. BOX 151 UPPER SANDUSKY, OH 43351 PHONE 1.800.262.1188 FAX 419.294.4980 WWW.WBMCGUIRE.COM</p>		
<p>JOB:</p>		
<p>LOCATION:</p>		
<p>CONTRACTOR:</p>	<p>ARCHITECT:</p>	
<p>APPROVED BY SIGNATURE:</p>		